

**TSS 5.00/04/135 3.3SN GN BX**

**Weidmüller Interface GmbH & Co. KG**  
Klingenbergstraße 26  
D-32758 Detmold  
Germany

www.weidmueller.com

**General ordering data**

Order No.	<a href="#">2651160000</a>
Type	TSS 5.00/04/135 3.3SN GN BX
GTIN (EAN)	4050118635812
Qty.	162 pc(s).
Product data	IEC: 630 V / 20 A / 0.2 - 2.5 mm <sup>2</sup> UL: 300 V / 20 A / AWG 30 - AWG 12
Packaging	Box

Creation date April 16, 2021 7:09:03 AM CEST

Catalogue status 09.04.2021 / We reserve the right to make technical changes.

## TSS 5.00/04/135 3.3SN GN BX

Weidmüller Interface GmbH &amp; Co. KG

Klingenbergstraße 26

D-32758 Detmold

Germany

www.weidmueller.com

## Technical data

## Dimensions and weights

Net weight	9.6 g
------------	-------

## System parameters

Product family	OMNIMATE basic – Series TSS	Wire connection method	Clamping yoke connection
Mounting onto the PCB	THT solder connection	Conductor outlet direction	135°
Pitch in mm (P)	5 mm	Pitch in inches (P)	0.197 inch
Number of poles	4	Pin series quantity	1
Solder pin length (l)	3.3 mm	Solder pin dimensions	0.8 x 0.9mm
Solder eyelet hole diameter (D)	1.5 mm	Number of solder pins per pole	1
Screwdriver blade	0.6 x 3.5	Tightening torque, min.	0.5 Nm
Tightening torque, max.	0.55 Nm	Clamping screw	M 3
Stripping length	7.5 mm	L1 in mm	15 mm
L1 in inches	0.591 inch		

## Material data

Insulating material	PA	Colour	Pale green
Colour chart (similar)	RAL 6021	Insulating material group	I
UL 94 flammability rating	V-0	Contact material	Copper alloy
Contact surface	tinned	Tinning type	matt
Storage temperature, min.	-40 °C	Storage temperature, max.	70 °C
Operating temperature, min.	-40 °C	Operating temperature, max.	105 °C

## Conductors suitable for connection

Clamping range, min.	0.2 mm <sup>2</sup>	Clamping range, max.	2.5 mm <sup>2</sup>
Wire connection cross section AWG, min.	AWG 30	Wire connection cross section AWG, max.	AWG 12
Solid, min. H05(07) V-U	0.2 mm <sup>2</sup>	Solid, max. H05(07) V-U	2.5 mm <sup>2</sup>
Flexible, min. H05(07) V-K	0.2 mm <sup>2</sup>	Flexible, max. H05(07) V-K	1.5 mm <sup>2</sup>
w. plastic collar ferrule, DIN 46228 pt 4, min.	0.2 mm <sup>2</sup>	w. plastic collar ferrule, DIN 46228 pt 4, max.	1.5 mm <sup>2</sup>
w. wire end ferrule, DIN 46228 pt 1, min.	0.2 mm <sup>2</sup>	w. wire end ferrule, DIN 46228 pt 1, max.	1.5 mm <sup>2</sup>

## Rated data acc. to IEC

Rated current, min. number of poles (Tu=20°C)	20 A	Rated voltage for surge voltage class / pollution degree II/2	630 V
Rated voltage for surge voltage class / pollution degree III/2	400 V	Rated voltage for surge voltage class / pollution degree III/3	250 V
Rated impulse voltage for surge voltage class/ pollution degree II/2	4 kV	Rated impulse voltage for surge voltage class/ pollution degree III/2	4 kV
Rated impulse voltage for surge voltage class/ contamination degree III/3	4 kV		

## Rated data acc. to CSA

Rated voltage (Use group B / CSA)	300 V	Rated current (Use group B / CSA)	20 A
Wire cross-section, AWG, min.	AWG 30	Wire cross-section, AWG, max.	AWG 12

## TSS 5.00/04/135 3.3SN GN BX

Weidmüller Interface GmbH &amp; Co. KG

Klingenbergstraße 26

D-32758 Detmold

Germany

www.weidmueller.com

## Technical data

## Rated data acc. to UL 1059

Institute (cURus)



Certificate No. (cURus)

E60693

Rated voltage (Use group B / UL 1059) 300 V

Rated current (Use group B / UL 1059) 20 A

Wire cross-section, AWG, min. AWG 30

Wire cross-section, AWG, max. AWG 12

Reference to approval values

Specifications are maximum values, details - see approval certificate.

## Packing

Packaging	Box	VPE length	0
VPE width	0	VPE height	0

## Classifications

ETIM 6.0	EC002643	ETIM 7.0	EC002643
ECLASS 9.0	27-44-04-01	ECLASS 9.1	27-44-04-01
ECLASS 10.0	27-44-04-01	ECLASS 11.0	27-46-01-01

## Important note

Notes

- Only compatible with OMNIMATE basic products
- P on drawing = pitch
- Rated current related to rated cross-section & min. No. of poles.
- Rated data refer only to the component itself. Clearance and creepage distances to other components are to be designed in accordance with the relevant application standards.
- In the case of a two-pole terminal, the insulating body must be held against the terminal when tightening the screw.
- Long term storage of the product with average temperature of 50 °C and average humidity 70%, 36 months

## Approvals

Approvals



ROHS Conform

UL File Number Search E60693

## Downloads

Brochure/Catalogue [Catalogues in PDF-format](#)

**TSS 5.00/04/135 3.3SN GN BX**

**Weidmüller Interface GmbH & Co. KG**  
 Klingenbergstraße 26  
 D-32758 Detmold  
 Germany

www.weidmueller.com

**Drawings**

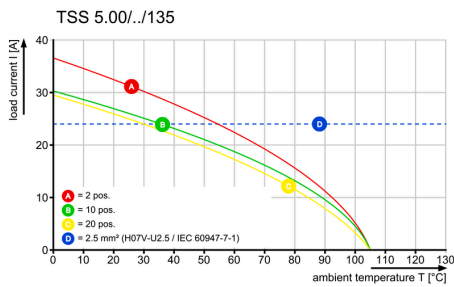
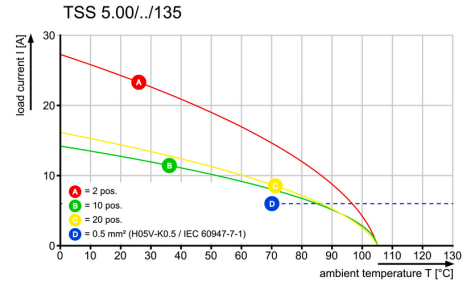
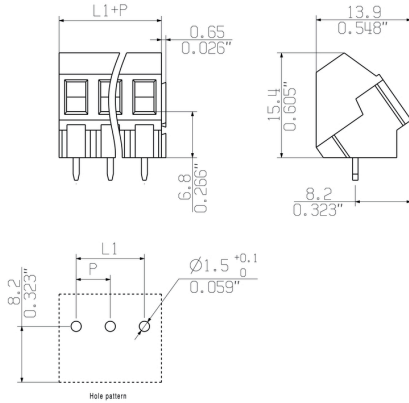

## Recommended wave soldering profiles

**Weidmüller Interface GmbH & Co. KG**  
 Klingenbergstraße 16  
 D-32758 Detmold  
 Germany  
 Fon: +49 5231 14-0  
 Fax: +49 5231 14-292083  
 www.weidmueller.com

### Single Wave:



### Double Wave:



### Wave soldering profiles

Wired connection elements should be processed in accordance with the DIN EN 61760-1 standard. We have included two recommendations for practical wave soldering profiles, with which Weidmüller PCB terminals and connectors are qualified.

When choosing a suitable profile for your application, the following factors also need to be considered:

- PCB thickness
- Proportion of Cu in the layers
- Single/double-sided assembly
- Product range
- Heating and cooling rates

The single and double wave profiles each indicate the recommended operating range, including the maximum soldering temperature of 260°C. In practice, the maximum soldering temperature is quite often well below the above maximum profile.