



Main

Range of product	Modicon TM7
Product or component type	Discrete I/O expansion block
Range compatibility	Modicon LMC058 Modicon M258
Enclosure material	Plastic
Bus type	TM7 bus
[Ue] rated operational voltage	24 V DC
Input/Output number	8
Input/Output number of block	8 I/O

Complementary

Discrete input number	0..8 input(s) configurable by software
Discrete input voltage	24 V
Discrete input voltage type	DC
Discrete input current	4.4 mA
Discrete input logic	Positive
Discrete output number	0..8 output(s) at <= 0.5 A, configurable by software with transistor protection
Discrete output voltage	24 V
Discrete output voltage type	DC
Sensor power supply	24 V, 500 mA for all channels with overload, short-circuit and reverse polarity protection
Electrical connection	8 female connectors M8 - 3 ways for sensor or actuator 1 female connector M8 - 4 ways for power OUT 1 male connector M8 - 4 ways for power IN 1 female connector M12 - B coding - 4 ways for bus OUT 1 male connector M12 - B coding - 4 ways for bus IN
Local signalling	2 LEDs for sensor power supply diagnostics 2 LEDs for bus diagnostic
Operating position	Any position
Fixing mode	By 2 screws
Product weight	0.19 kg

Environment

Standards	IEC 61131-2
Product certifications	C-Tick CURus GOST-R ATEX II 3g EEx nA II T5
Marking	CE
Ambient air temperature for operation	-10...60 °C
Ambient air temperature for storage	-25...85 °C
Relative humidity	5...95 % without condensation or dripping water
Pollution degree	2 conforming to IEC 60664
IP degree of protection	IP67 conforming to IEC 61131-2
Operating altitude	0...2000 m
Storage altitude	0...3000 m

Vibration resistance	4 gn constant acceleration (f = 200...500 Hz) conforming to IEC 60721-3-5 Class 5M3 2 gn constant acceleration (f = 8...200 Hz) conforming to IEC 60721-3-5 Class 5M3 7.5 mm constant amplitude (f = 2...8 Hz) conforming to IEC 60721-3-5 Class 5M3
Shock resistance	30 gn for 11 ms conforming to IEC 60721-3-5 Class 5M3
Electromagnetic compatibility	Conducted and radiated emissions conforming to CISPR 11 Conducted RF disturbances conforming to EN/IEC 61000-4-6 1.2/50 µs shock waves immunity test (level: 1 kV - shielded links (differential mode)) conforming to EN/IEC 61000-4-5 1.2/50 µs shock waves immunity test (level: 0.5 kV - shielded links (common mode)) conforming to EN/IEC 61000-4-5 1.2/50 µs shock waves immunity test (level: 1 kV - unshielded links (differential mode)) conforming to EN/IEC 61000-4-5 1.2/50 µs shock waves immunity test (level: 0.5 kV - unshielded links (common mode)) conforming to EN/IEC 61000-4-5 1.2/50 µs shock waves immunity test (level: 1 kV - power supply (differential mode)) conforming to EN/IEC 61000-4-5 1.2/50 µs shock waves immunity test (level: 0.5 kV - power supply (common mode)) conforming to EN/IEC 61000-4-5 Electrical fast transient/burst immunity test (level: 1 kV - shielded cable) conforming to EN/IEC 61000-4-4 Electrical fast transient/burst immunity test (level: 1 kV - input/output) conforming to EN/IEC 61000-4-4 Electrical fast transient/burst immunity test (level: 2 kV - power supply) conforming to EN/IEC 61000-4-4 Susceptibility to electromagnetic fields (level: 10 V/m - 80...2000 MHz) conforming to EN/IEC 61000-4-3 Susceptibility to electromagnetic fields (level: 1 V/m - 2...2.7 GHz) conforming to EN/IEC 61000-4-3 Electrostatic discharge immunity test (level: 8 kV - in air) conforming to EN/IEC 61000-4-2 Electrostatic discharge immunity test (level: 4 kV - on contact) conforming to EN/IEC 61000-4-2

Offer Sustainability

Sustainable offer status	Green Premium product
RoHS (date code: YYWW)	Compliant - since 1039 - Schneider Electric declaration of conformity
REACH	Reference not containing SVHC above the threshold
Product environmental profile	Available Download Product Environmental
Product end of life instructions	Available Download End Of Life Manual

Digital Mixed Block

Description

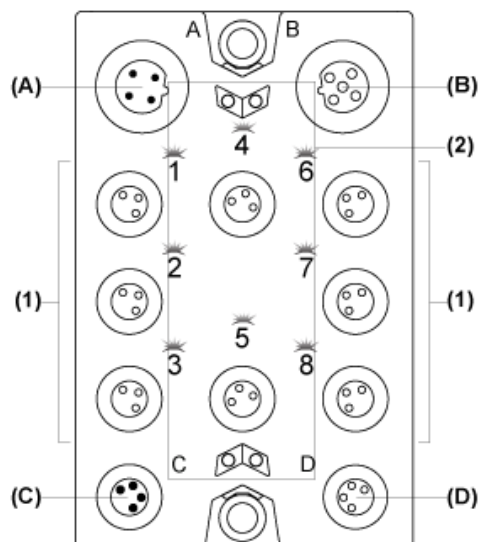

- (A) TM7 bus IN connector
- (B) TM7 bus OUT connector
- (C) 24 Vdc power IN connector
- (D) 24 Vdc power OUT connector
- (1) Input / Output connectors
- (2) Status LEDs

Connector and Channel Assignments

I/O connectors	Channel types	Channels
1	Input/Output	I0/Q0
2	Input/Output	I1/Q1
3	Input/Output	I2/Q2
4	Input/Output	I3/Q3
5	Input/Output	I4/Q4
6	Input/Output	I5/Q5
7	Input/Output	I6/Q6
8	Input/Output	I7/Q7

TM7 Block, Size 1

Dimensions

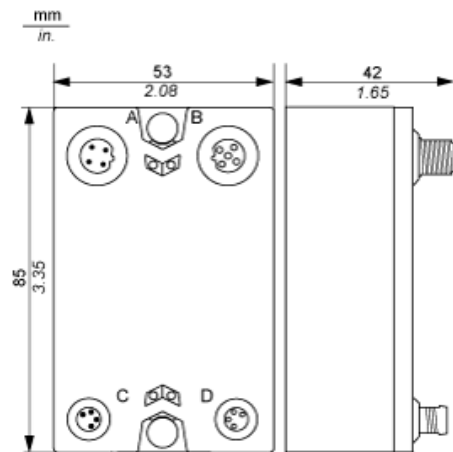

Spacing Requirements

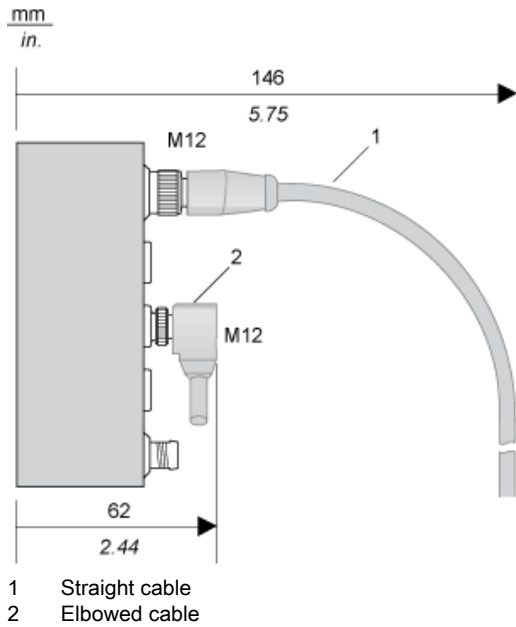

Installation Guidelines

TM7 Block on an Aluminium Frame

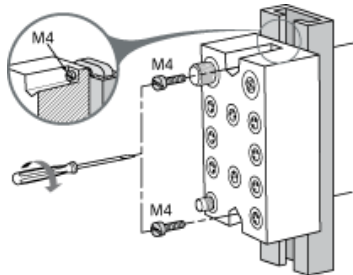

NOTE: Maximum torque to fasten the required M4 screws is 0.6 N.m (5.3 lbf-in).

TM7 Block on a DIN Rail

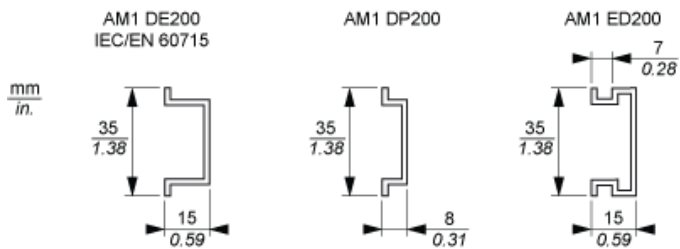

NOTE: Only size 1 (smallest) blocks can be installed on DIN rail with the TM7ACMP mounting plate.

TM7 Block Directly on the Machine

Drilling template of the block:

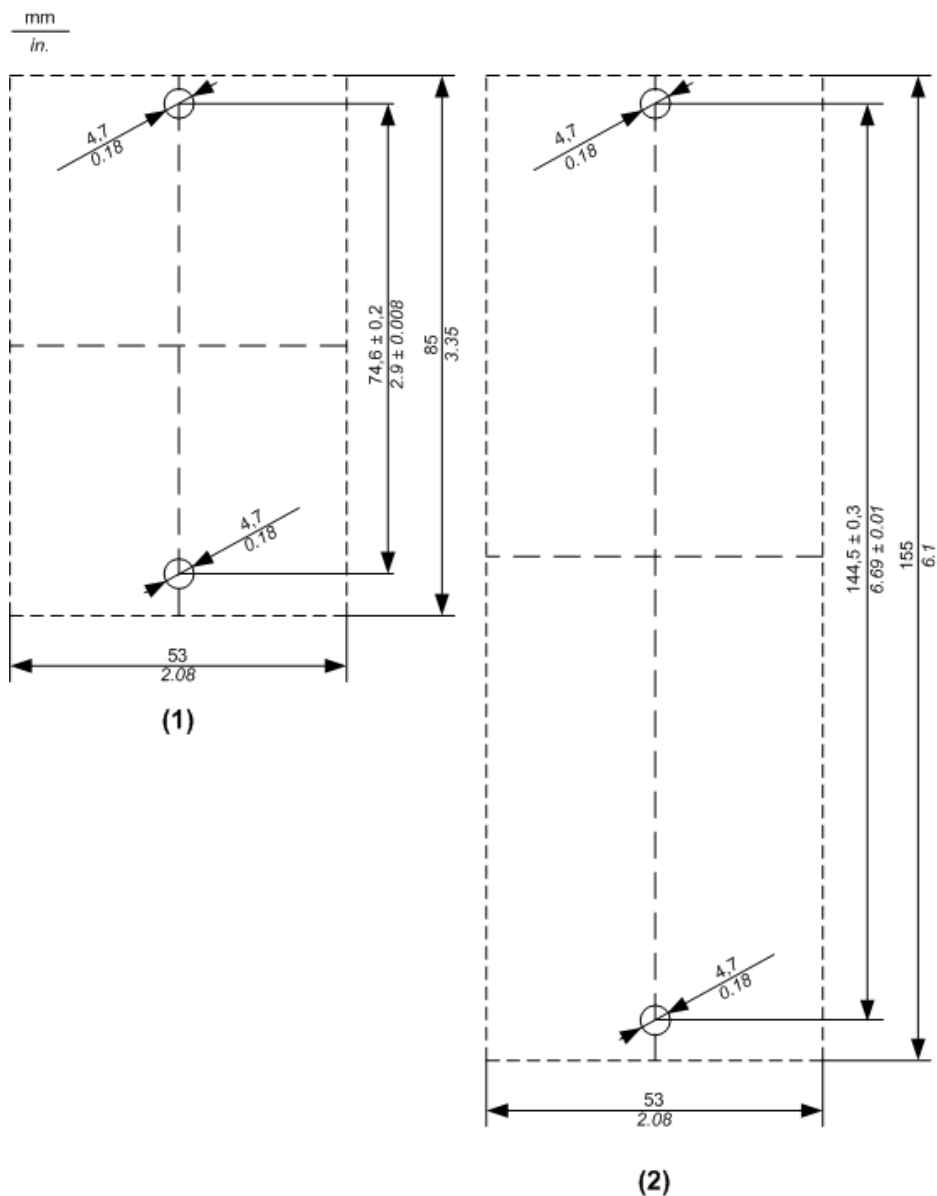

- (1) Size 1
- (2) Size 2

The thickness of the base plate should be taken into consideration when defining the screw length.

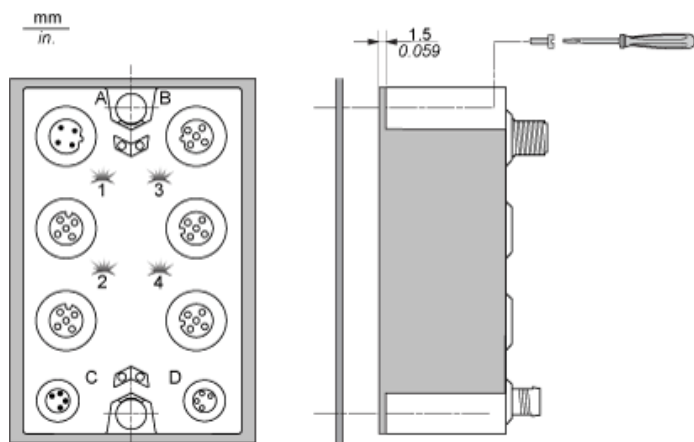

NOTE: Maximum torque to fasten the required M4 screws is 0.6 N.m (5.3 lbf-in).

Wiring Diagram

Pin Assignments for I/O Connectors

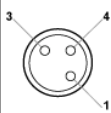
Connection	Pin	M8 input / output
	1	24 Vdc sensor / actuator supply
3	0 Vdc	
4	DI/DO: input/ output signal	

Wiring the Power Supply

When you provide power to a TM7 I/O block using the 24 VDC Power OUT connector of the preceding I/O block, both blocks occupy the same 24 Vdc I/O power segment. However, if you connect an external isolated power supply to the 24 Vdc Power IN connector of a TM7 I/O block, you establish a new 24 Vdc I/O power segment beginning with that I/O block.

I/O block wired with one external 24 Vdc power supply:

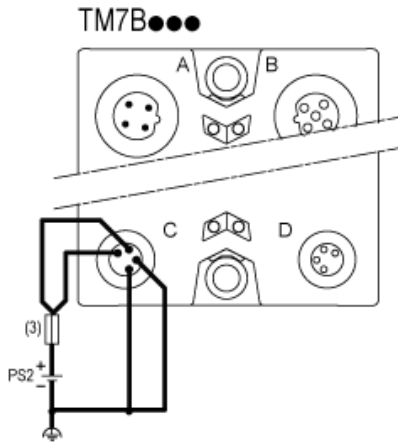

- (3) External fuse, Type T slow-blow, 8 A max., 250 V
- PS2 External isolated I/O power supply, 24 Vdc

Switching Inductive Load Characteristics

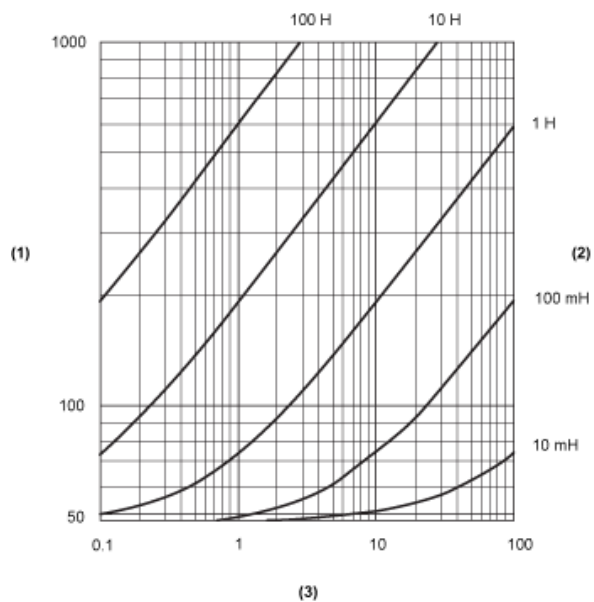

- (1) Load resistance in Ω
- (2) Load inductance in H
- (3) Max. operating cycles / second