

BMXAMM0600H

mixed analog I/O module M340 - 4 inputs 0..20 mA - 2 outputs 0..20 mA



Main

Range of product	Modicon M340 automation platform
Product or component type	Mixed analog I/O module
Product specific application	For severe environments
Electrical connection	1 connector 20 ways
Isolation between channels	Non isolated
Input level	High level
Analogue input number	4
Analogue input type	Voltage 1...5 V Voltage 0...5 V Voltage 0...10 V Voltage +/- 10 V Current 4...20 mA Current 0...20 mA

Complementary

Analogue input resolution	14 bits +/- 10 V 13 bits 0...10 V 12 bits 4...20 mA 12 bits 1...5 V 12 bits 0...5 V 12 bits 0...20 mA
Permitted overload on inputs	+/- 30 V 1...5 V +/- 30 V 0...5 V +/- 30 V 0...10 V +/- 30 V +/- 10 V +/- 30 mA 4...20 mA +/- 30 mA 0...20 mA
Internal conversion resistor	250 Ohm
Precision of internal conversion resistor	0.1 % - 15 ppm/°C
Type of filter	First order digital filtering by firmware
Fast read cycle time	1 ms + 1 ms x number of channels used
Nominal read cycle time	5 ms for 4 channels
Measurement error	<= 0.8 % of full scale 4...20 mA - 25...70 °C <= 0.8 % of full scale 0...20 mA - 25...70 °C <= 0.8 % of full scale +/- 10 V - 25...70 °C <= 0.6 % of full scale 4...20 mA - 25...70 °C <= 0.6 % of full scale 0...20 mA - 25...70 °C <= 0.4 % of full scale 1...5 V - 25...70 °C <= 0.4 % of full scale 0...5 V - 25...70 °C <= 0.4 % of full scale 0...10 V - 25...70 °C <= 0.4 % of full scale +/- 10 V - 25...70 °C 0.35 % of full scale 4...20 mA 25 °C 0.35 % of full scale 0...20 mA 25 °C 0.25 % of full scale 1...5 V 25 °C 0.25 % of full scale 0...5 V 25 °C 0.25 % of full scale 0...10 V 25 °C 0.25 % of full scale +/- 10 V +/- 10 V 25 °C 0.25 % of full scale 4...20 mA 25 °C 0.25 % of full scale 0...20 mA 25 °C

The information provided in this documentation contains general descriptions and/or technical characteristics of the performance of the products contained herein. This documentation is not intended as a substitute for and is not to be used for determining suitability or reliability of these products for specific user applications. It is the duty of any such user or integrator to perform the appropriate and complete risk analysis, evaluation and testing of the products with respect to the relevant specific application or use thereof. Neither Schneider Electric Industries SAS nor any of its affiliates or subsidiaries shall be responsible or liable for misuse of the information contained herein.

Temperature drift	50 ppm/°C 4...20 mA 50 ppm/°C 0...20 mA 30 ppm/°C 1...5 V 30 ppm/°C 0...5 V 30 ppm/°C 0...10 V 30 ppm/°C +/- 10 V 100 ppm/°C 4...20 mA 100 ppm/°C 0...20 mA 100 ppm/°C +/- 10 V
Recalibration	Factory calibrated on outputs Internal on inputs
Isolation voltage	750 V DC between group of I/O channels 1400 V DC between channels and bus 1400 V DC between channels and ground
Output level	High level
Analogue output number	2
Analogue output type	Voltage +/- 10 V Current 4...20 mA Current 0...20 mA
Analogue output resolution	12 bits +/- 10 V 11 bits 4...20 mA 11 bits 0...20 mA
Conversion time	<= 2 ms
Maximum conversion value	0...24 mA 4...20 mA 0...24 mA 0...20 mA +/- 11.25 V 1...5 V +/- 11.25 V 0...5 V +/- 11.25 V 0...10 V 0...30 mA 4...20 mA 0...30 mA 0...20 mA +/- 11.25 V +/- 10 V +/- 10 V
Fallback mode	Configurable Predefined
Status LED	1 LED red I/O 1 LED red ERR 1 LED per channel green channel diagnostic 1 LED green RUN
Product weight	0.155 kg
Current consumption	130 mA at 24 V DC 150 mA at 3.3 V DC

Environment

Ambient air temperature for operation	-25...70 °C
Relative humidity	10...95 % without condensation
IP degree of protection	IP20
Protective treatment	Conformal coating Humiseal 1A33 TC
Environmental characteristic	3C4 conforming to EN/IEC 60721-3-3 3C3 conforming to EN/IEC 60721-3-3

Offer Sustainability

Sustainable offer status	Not Green Premium product
RoHS (date code: YYWW)	Compliant - since 0911 - Schneider Electric declaration of conformity
REACH	Reference not containing SVHC above the threshold
Product environmental profile	Available Download Product Environmental

Modules Mounted on Racks

Dimensions



- (1) With removable terminal block (cage, screw or spring).
- (2) With FCN connector.
- (3) On AM1 ED rail: 35 mm wide, 15 mm deep. Only possible with BMXXBP0400/0400H/0600/0600H/0800/0800H rack.

Rack references	a in mm	a in in.
BMXXBP0400 and BMXXBP0400H	242.4	09.54
BMXXBP0600 and BMXXBP0600H	307.6	12.11
BMXXBP0800 and BMXXBP0800H	372.8	14.68
BMXXBP1200 and BMXXBP1200H	503.2	19.81

Wiring Diagram

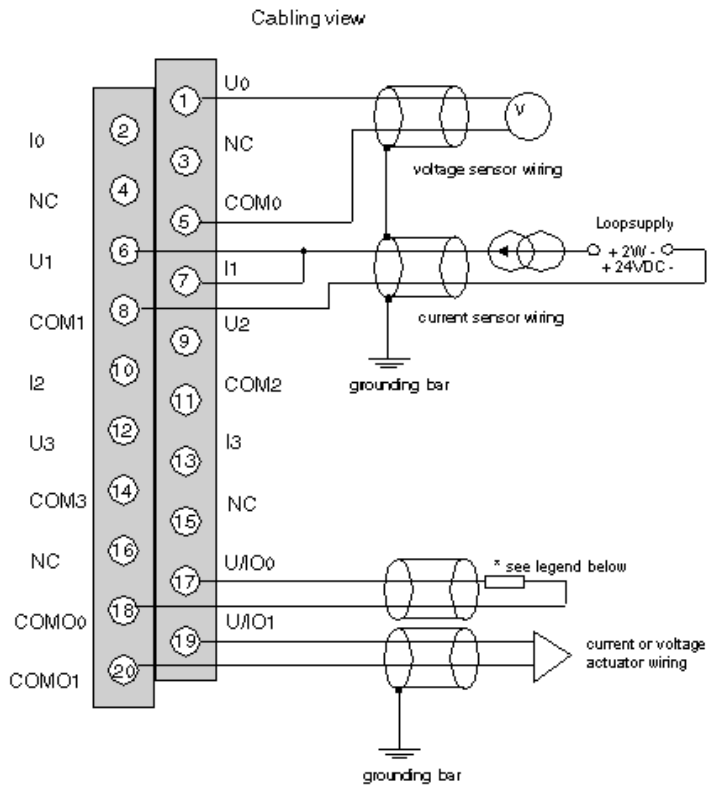

Ux + pole input for channel x
 COMx pole input for channel x
 U/ + pole output for channel x
 IOx
 COM0 pole output for channel x

* The current loop is self-powered by the output and does not request any external supply.