



Main

Range of product	Modicon M340 automation platform
Product or component type	Analog input module
Product specific application	For severe environments
Electrical connection	1 connector 28 ways
Isolation between channels	Isolated
Input level	High level
Analogue input number	8
Analogue input type	Voltage 1...5 V Voltage 0...5 V Voltage 0...10 V Voltage +/- 5 V Voltage +/- 10 V Current 4...20 mA Current 0...20 mA Current +/- 20 mA

Complementary

Analog/Digital conversion	16 bits
Analogue input resolution	15 bits + sign
Input impedance	10 MOhm
Permitted overload on inputs	+/- 30 mA +/- 20 mA +/- 30 V 1...5 V +/- 30 V 0...5 V +/- 30 V 0...10 V +/- 30 V +/- 5 V +/- 30 V +/- 10 V +/- 30 mA 4...20 mA +/- 30 mA 0...20 mA
Internal conversion resistor	250 Ohm
Precision of internal conversion resistor	0.1 % - 15 ppm/°C
Type of filter	First order digital filtering
Fast read cycle time	1 ms + 1 ms x number of channels used
Nominal read cycle time	9 ms for 8 channels
Measurement error	<= 0.3 % of full scale 4...20 mA - 25...70 °C <= 0.3 % of full scale 0...20 mA - 25...70 °C <= 0.3 % of full scale +/- 20 mA - 25...70 °C <= 0.1 % of full scale 1...5 V - 25...70 °C <= 0.1 % of full scale 0...5 V - 25...70 °C <= 0.1 % of full scale 0...10 V - 25...70 °C <= 0.1 % of full scale +/- 5 V - 25...70 °C <= 0.1 % of full scale +/- 10 V - 25...70 °C 0.08 % of full scale +/- 5 V 25 °C 0.08 % of full scale 1...5 V 25 °C 0.08 % of full scale 0...5 V 25 °C 0.08 % of full scale 0...10 V 25 °C 0.08 % of full scale +/- 10 V 25 °C <= 0.2 % of full scale +/- 10 V - 25...70 °C 0.15 % of full scale 4...20 mA 25 °C 0.15 % of full scale 0...20 mA 25 °C 0.15 % of full scale +/- 20 mA 25 °C
Temperature drift	50 ppm/°C 30 ppm/°C
Common mode between channels	>= 80 dB
Digital value format	+/- 10000 by default +/- 32000 in user scale

The information provided in this documentation contains general descriptions and/or technical characteristics of the performance of the products contained herein. This documentation is not intended as a substitute for and is not to be used for determining suitability or reliability of these products for specific user applications. It is the duty of any such user or integrator to perform the appropriate and complete risk analysis, evaluation and testing of the products with respect to the relevant specific application or use thereof. Neither Schneider Electric Industries SAS nor any of its affiliates or subsidiaries shall be responsible or liable for misuse of the information contained herein.

Isolation voltage	1400 V DC between channels and bus 1400 V DC between channels and ground 300 V DC between channels
Measurement resolution	1.4 μ A 4...20 mA 1.4 μ A 0...20 mA 1.4 μ A +/- 20 mA 0.36 mV +/- 5 V 0.36 mV 1...5 V 0.36 mV 0...5 V 0.36 mV 0...10 V 0.36 mV +/- 10 V
Maximum conversion value	0...30 mA +/- 5 V 0...30 mA 4...20 mA 0...30 mA 0...20 mA 0...30 mA +/- 20 mA +/- 11.4 V 1...5 V +/- 11.4 V 0...5 V +/- 11.4 V 0...10 V +/- 11.4 V +/- 10 V
Status LED	1 LED red I/O 1 LED red ERR 1 LED per channel green channel diagnostic 1 LED green RUN
Product weight	0.175 kg
Current consumption	45 mA at 24 V DC 150 mA at 3.3 V DC

Environment

Ambient air temperature for operation	-25...70 °C
Relative humidity	10...95 % without condensation
IP degree of protection	IP20
Protective treatment	Conformal coating Humiseal 1A33 TC
Environmental characteristic	3C4 conforming to EN/IEC 60721-3-3 3C3 conforming to EN/IEC 60721-3-3

Offer Sustainability

Sustainable offer status	Not Green Premium product
RoHS (date code: YYWW)	Compliant - since 1206 - Schneider Electric declaration of conformity
REACH	Reference not containing SVHC above the threshold
Product environmental profile	Available Download Product Environmental

Modules Mounted on Racks

Dimensions

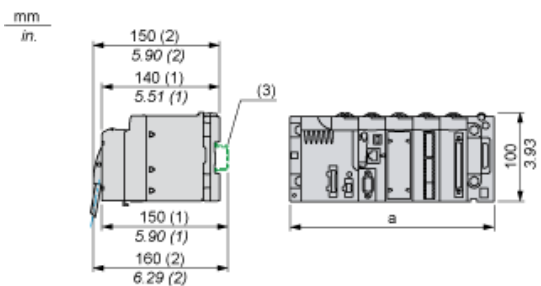

- (1) With removable terminal block (cage, screw or spring).
- (2) With FCN connector.
- (3) On AM1 ED rail: 35 mm wide, 15 mm deep. Only possible with BMXXBP0400/0400H/0600/0600H/0800/0800H rack.

Rack references	a in mm	a in in.
BMXXBP0400 and BMXXBP0400H	242.4	09.54
BMXXBP0600 and BMXXBP0600H	307.6	12.11
BMXXBP0800 and BMXXBP0800H	372.8	14.68
BMXXBP1200 and BMXXBP1200H	503.2	19.81

Wiring Diagram

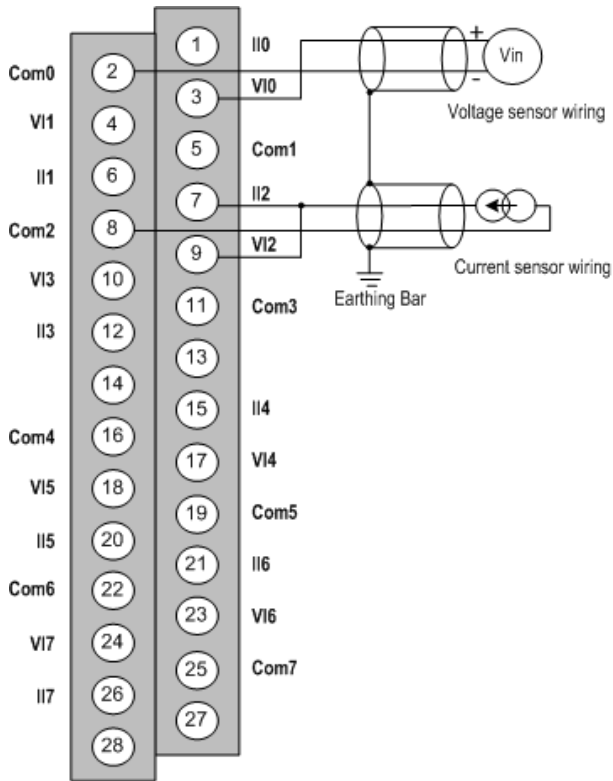

V1x + pole input for channel x
 COM x pole input for channel x
 I1x current reading resistor + input
 Channel voltage sensor
 0
 Channel wire current sensor
 1