

LX 15.00/02/90 4.5SN BK BX

Weidmüller Interface GmbH & Co. KG

Klingenbergstraße 26

D-32758 Detmold

Germany

www.weidmueller.com

Product image



Similar to illustration

High-performance PCB terminal with proven clamping yoke connection at 15.00 mm pitch, conductor outlet direction in 90° design. Version and test point.

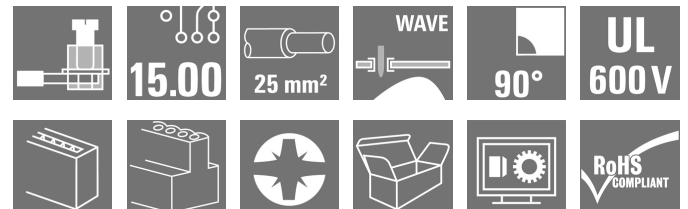

General ordering data

Version	Printed circuit board terminals, 15.00 mm, Number of poles: 2, 90°, Solder pin length (l): 4.5 mm, tinned, black, Clamping yoke connection, Clamping range, max. : 25 mm ² , Box
Order No.	1226470000
Type	LX 15.00/02/90 4.5SN BK BX
GTIN (EAN)	4050118011319
Qty.	20 pc(s).
Product data	IEC: 1000 V / 101 A / 1.5 - 25 mm ² UL: 600 V / 85 A / AWG 16 - AWG 4
Packaging	Box

Creation date March 23, 2021 9:54:10 AM CET

LX 15.00/02/90 4.5SN BK BX

Weidmüller Interface GmbH & Co. KG

Klingenbergstraße 26

D-32758 Detmold

Germany

www.weidmueller.com

Technical data

Dimensions and weights

Depth	29.1 mm	Depth (inches)	1.146 inch
Height	41.5 mm	Height (inches)	1.634 inch
Height of lowest version	37 mm	Net weight	34.7 g
Width	28 mm	Width (inches)	1.102 inch

System parameters

Product family	OMNIMATE Power - series LX	Wire connection method	Clamping yoke connection
Mounting onto the PCB	THT solder connection	Conductor outlet direction	90°
Pitch in mm (P)	15 mm	Pitch in inches (P)	0.591 inch
Number of poles	2	Pin series quantity	1
Fitted by customer	No	Max. adjacent poles per row	10
Solder pin length (l)	4.5 mm	Solder pin dimensions	1.2 x 1.2 mm
Solder eyelet hole diameter (D)	1.6 mm	Solder eyelet hole diameter tolerance (D)+	0,1 mm
Number of solder pins per pole	4	Screwdriver blade	1.0 x 5.5
Screwdriver blade standard	DIN 5264	Tightening torque, min.	2.4 Nm
Tightening torque, max.	4 Nm	Clamping screw	M 5
Stripping length	16 mm	L1 in mm	15 mm
L1 in inches	0.591 inch	Touch-safe protection acc. to DIN VDE 0470	IP 10
Touch-safe protection acc. to DIN VDE 57 106	Safe from finger touch	Volume resistance	0.50 mΩ

Material data

Insulating material	Wemid (PA)	Colour	black
Colour chart (similar)	RAL 9011	Insulating material group	I
Comparative Tracking Index (CTI)	≥ 600	UL 94 flammability rating	V-0
Contact material	E-Cu	Contact surface	tinned
Layer structure of solder connection	1.5...3 μm Ni / 4...6 μm Sn matt	Storage temperature, min.	-40 °C
Storage temperature, max.	70 °C	Operating temperature, min.	-50 °C
Operating temperature, max.	120 °C	Temperature range, installation, min.	-25 °C
Temperature range, installation, max.	120 °C		

Conductors suitable for connection

Clamping range, min.	1.31 mm ²
Clamping range, max.	25 mm ²
Wire connection cross section AWG, min.	AWG 16
Wire connection cross section AWG, max.	AWG 4
Solid, min. H05(07) V-U	1.5 mm ²
Solid, max. H05(07) V-U	16 mm ²
Stranded, min. H07V-R	6 mm ²
Stranded, max. H07V-R	25 mm ²
Flexible, min. H05(07) V-K	1.5 mm ²
Flexible, max. H05(07) V-K	25 mm ²
w. plastic collar ferrule, DIN 46228 pt 4, min.	1.5 mm ²
w. plastic collar ferrule, DIN 46228 pt 4, max.	16 mm ²
w. wire end ferrule, DIN 46228 pt 1, min.	1.5 mm ²

Creation date March 23, 2021 9:54:10 AM CET

LX 15.00/02/90 4.5SN BK BX

Weidmüller Interface GmbH & Co. KG
 Klingenbergstraße 26
 D-32758 Detmold
 Germany

www.weidmueller.com

Technical data

w. wire end ferrule, DIN 46228 pt 1, max. 16 mm²

Plug gauge in accordance with EN 60999 a x b; ø 6.9 mm x 6.9 mm

Clampable conductor	Cross-section for conductor connection	Type	fine-wired
		nominal	4 mm ²
wire end ferrule	Stripping length	nominal	15 mm
		Recommended wire-end ferrule	H4.0/15
Cross-section for conductor connection	Type	fine-wired	
		nominal	6 mm ²
wire end ferrule	Stripping length	nominal	15 mm
		Recommended wire-end ferrule	H6.0/15
Cross-section for conductor connection	Type	fine-wired	
		nominal	10 mm ²
wire end ferrule	Stripping length	nominal	15 mm
		Recommended wire-end ferrule	H10.0/15
Cross-section for conductor connection	Type	fine-wired	
		nominal	16 mm ²
wire end ferrule	Stripping length	nominal	15 mm
		Recommended wire-end ferrule	H16.0/15

Reference text Length of ferrules is to be chosen depending on the product and the rated voltage., The outside diameter of the plastic collar should not be larger than the pitch (P)

Rated data acc. to IEC

tested acc. to standard	IEC 60664-1, IEC 61984	Rated current, min. number of poles (Tu=20°C)	101 A
Rated current, max. number of poles (Tu=20°C)	101 A	Rated current, min. number of poles (Tu=40°C)	101 A
Rated current, max. number of poles (Tu=40°C)	101 A	Rated voltage for surge voltage class / pollution degree II/2	1,000 V
Rated voltage for surge voltage class / pollution degree III/2	1,000 V	Rated voltage for surge voltage class / pollution degree III/3	1,000 V
Rated impulse voltage for surge voltage class/ pollution degree II/2	6 kV	Rated impulse voltage for surge voltage class/ pollution degree III/2	8 kV
Rated impulse voltage for surge voltage class/ contamination degree III/3	8 kV	Short-time withstand current resistance	3 x 1s mit 1000 A

Rated data acc. to CSA

Rated voltage (Use group B / CSA)	600 V	Rated voltage (Use group C / CSA)	600 V
Rated voltage (Use group D / CSA)	600 V	Rated current (Use group B / CSA)	85 A
Rated current (Use group C / CSA)	85 A	Rated current (Use group D / CSA)	5 A
Wire cross-section, AWG, min.	AWG 16	Wire cross-section, AWG, max.	AWG 4

LX 15.00/02/90 4.5SN BK BX

Weidmüller Interface GmbH & Co. KG
 Klingenbergstraße 26
 D-32758 Detmold
 Germany

www.weidmueller.com

Technical data

Rated data acc. to UL 1059

Institute (UR)



Certificate No. (UR)

E60693

Rated voltage (Use group B / UL 1059) 600 V

Rated voltage (Use group C / UL 1059) 600 V

Rated voltage (Use group D / UL 1059) 600 V

Rated current (Use group B / UL 1059) 85 A

Rated current (Use group C / UL 1059) 85 A

Rated current (Use group D / UL 1059) 5 A

Wire cross-section, AWG, min. AWG 16

Wire cross-section, AWG, max. AWG 4

Reference to approval values

Specifications are maximum values, details - see approval certificate.

Packing

Packaging	Box	VPE length	50 mm
VPE width	122 mm	VPE height	175 mm

Classifications

ETIM 6.0	EC002643	ETIM 7.0	EC002643
ECLASS 9.0	27-44-04-01	ECLASS 9.1	27-44-04-01
ECLASS 10.0	27-44-04-01	ECLASS 11.0	27-46-01-01

Important note

IPC conformity

Conformity: The products are developed, manufactured and delivered according international recognized standards and norms and comply with the assured properties in the data sheet resp. fulfill decorative properties in accordance with IPC-A-610 "Class 2". Further claims on the products can be evaluated on request.

Notes

- Additional colours on request
- Rated current related to rated cross-section & min. No. of poles.
- Wire end ferrule without plastic collar to DIN 46228/1
- Wire end ferrule with plastic collar to DIN 46228/4
- P on drawing = pitch
- Rated data refer only to the component itself. Clearance and creepage distances to other components are to be designed in accordance with the relevant application standards.
- The test point can only be used as potential-pickup point.
- Long term storage of the product with average temperature of 50 °C and average humidity 70%, 36 months

Approvals

Approvals



ROHS

Conform

UL File Number Search

E60693

Creation date March 23, 2021 9:54:10 AM CET

Catalogue status 12.03.2021 / We reserve the right to make technical changes.

Data sheet**LX 15.00/02/90 4.5SN BK BX****Weidmüller Interface GmbH & Co. KG**
Klingenbergstraße 26
D-32758 Detmold
Germany

www.weidmueller.com

Technical data**Downloads**

Approval/Certificate/Document of Conformity	Declaration of the Manufacturer
Engineering Data	STEP
Engineering Data	EPLAN, WSCAD
User Documentation	QR-Code product handling video

LX 15.00/02/90 4.5SN BK BX

Weidmüller Interface GmbH & Co. KG
 Klingenbergstraße 26
 D-32758 Detmold
 Germany

www.weidmueller.com

Drawings

Dimensional drawing

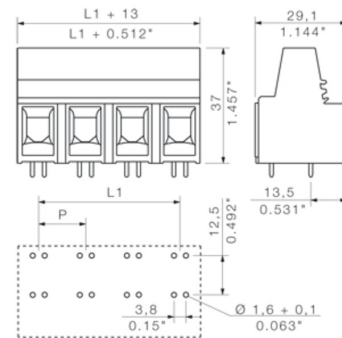

Graph

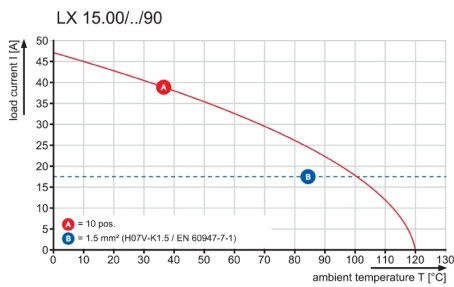

Graph



The reproduction, distribution and utilization of this document as well as the communication of its contents to others without explicit authorization is prohibited. Offenders will be held liable for the payment of damages. Weidmüller exclusively reserves the right to file for patents, utility models or designs.

© Weidmüller Interface GmbH & Co. KG



PS 2.0
Order NO. 031000 0000

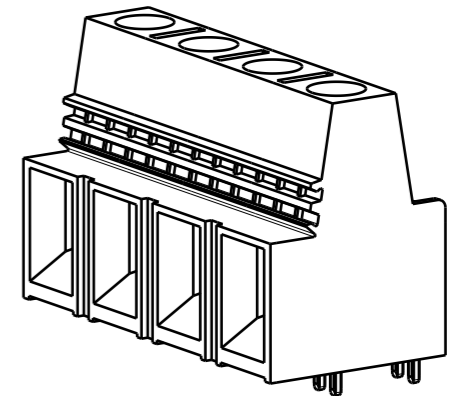

P = Pitch
n = No. of Poles
l = Pin length
Shown: LX15.00/04/90/...

PIN LENGTH l	TOLERANCE	n	L1 [mm]	L1 [Inch]
6,5	0/-0,35	10	135,00	5,315
4,5	0/-0,35	9	120,00	4,724
		8	105,00	4,134
		7	90,00	3,543
		6	75,00	2,953
		5	60,00	2,362
		4	45,00	1,772
		3	30,00	1,181
		2	15,00	0,591
		n	L1 [mm]	L1 [Inch]

For the mounting of PCBs, it should be noted that the rated data relates only to the PCB components alone. The necessary creepage and clearance paths must be observed in connection with the respective applicant in accordance to IEC 60664-1 (VDE 0110). The current-carrying capacity and pitch tolerance is to be determined according to DIN IEC 60326-3 very fine.

Weidmüller PCB components are tested to the IEC 60947-7-4 standard, and are valid for its field of application. Provided that the components are used to the intended purpose, all requirements with respect to the occurring of electrical, mechanical, thermic and corrosive stress will be satisfied.

GENERAL TOLERANCE:
DIN ISO 2768-m

	EC00000683	00	Prim PLM Part No.: 009292		Prim ERP Part No.: 1226480000	
	First Issue Date 14.05.2018	Max. nos.			29942 Drawing no. Issue no. Sheet 01 of 04 sheets	
	Modification					
	Drawn	03.12.2018	Date		Name	
	Responsible				Xiang, Keqin	
	Approved	04.12.2018			Xu, Shary	
Scale: 1/1	Size: A3	Drawings Assembly		LX.. 15.00/./90... LEITERPLATTENKLEMME PCB TERMINAL		
				Product file: 7234 LX 15.00		

Recommended wave soldering profiles

Weidmüller Interface GmbH & Co. KG
 Klingenbergstraße 16
 D-32758 Detmold
 Germany
 Fon: +49 5231 14-0
 Fax: +49 5231 14-292083
 www.weidmueller.com

Single Wave:



Double Wave:



Wave soldering profiles

Wired connection elements should be processed in accordance with the DIN EN 61760-1 standard. We have included two recommendations for practical wave soldering profiles, with which Weidmüller PCB terminals and connectors are qualified.

When choosing a suitable profile for your application, the following factors also need to be considered:

- PCB thickness
- Proportion of Cu in the layers
- Single/double-sided assembly
- Product range
- Heating and cooling rates

The single and double wave profiles each indicate the recommended operating range, including the maximum soldering temperature of 260°C. In practice, the maximum soldering temperature is quite often well below the above maximum profile.

