

SC-SMT 3.81/03/90LF 3.2SN BK RL
Weidmüller Interface GmbH & Co. KG

Klingenbergstraße 26

D-32758 Detmold

Germany

www.weidmueller.com

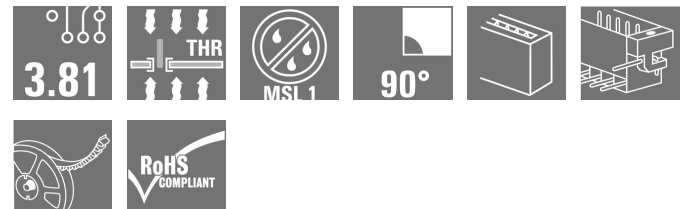
Product image

Similar to illustration

High-temperature-resistant pin header (SC-SMT 90LF) in 3.81-mm pitch (0.15 inch)

- Plugging direction parallel to PCB (recumbent)
- With solder flange (LF).
- Packed either in box (BX) or on anti-static roll (tape-on-reel, RL)
- Pin length of either 1.5 mm or 3.2 mm

Weidmüller's 3.81-mm-pitch (0.15 inch) plug-in connectors are compatible with the layouts of standard connectors and offer space for labelling.

General ordering data

Version	PCB plug-in connector, male header, Solder flange, THT/THR solder connection, 3.81 mm, Number of poles: 3, 90°, Solder pin length (l): 3.2 mm, tinned, black, Tape
Order No.	1863970000
Type	SC-SMT 3.81/03/90LF 3.2SN BK RL
GTIN (EAN)	4032248429219
Qty.	400 pc(s).
Product data	IEC: 320 V / 17.5 A UL: 300 V / 11 A
Packaging	Tape

Creation date March 25, 2021 10:15:53 PM CET

SC-SMT 3.81/03/90LF 3.2SN BK RL

Weidmüller Interface GmbH & Co. KG

Klingenbergstraße 26

D-32758 Detmold

Germany

www.weidmueller.com

Technical data

Dimensions and weights

Depth	9.2 mm	Depth (inches)	0.362 inch
Height	10.3 mm	Height (inches)	0.406 inch
Height of lowest version	7.1 mm	Net weight	2.518 g
Width	21.72 mm	Width (inches)	0.855 inch

System specifications

Product family	OMNIMATE Signal - series BC/SC 3.81	Type of connection	Board connection
Mounting onto the PCB	THT/THR solder connection	Pitch in mm (P)	3.81 mm
Pitch in inches (P)	0.15 inch	Outgoing elbow	90°
Number of poles	3	Number of solder pins per pole	1
Solder pin length (l)	3.2 mm	Solder pin length tolerance	0 / -0,02 mm
Solder pin dimensions	d = 1.0 mm, Octagonal	Solder pin dimensions = d tolerance	0 / -0,04 mm
Solder eyelet hole diameter (D)	1.3 mm	Solder eyelet hole diameter tolerance (D)	+ 0,1 mm
Outside diameter of solder pad	2.1 mm	Template aperture diameter	1.9 mm
L1 in mm	7.62 mm	L1 in inches	0.3 inch
Number of rows	1	Pin series quantity	1
Touch-safe protection acc. to DIN VDE 57 106	Safe from finger touch	Touch-safe protection acc. to DIN VDE 0470	IP 20
Volume resistance	≤5 mΩ	Can be coded	Yes

Material data

Insulating material	LCP GF	Colour	black
Colour chart (similar)	RAL 9011	Insulating material group	IIIa
Comparative Tracking Index (CTI)	≥ 175	Moisture Level (MSL)	1
UL 94 flammability rating	V-0	Contact material	Copper alloy
Contact surface	tinned	Storage temperature, min.	-40 °C
Storage temperature, max.	70 °C	Operating temperature, min.	-50 °C
Operating temperature, max.	120 °C	Temperature range, installation, min.	-25 °C
Temperature range, installation, max.	120 °C		

Rated data acc. to IEC

tested acc. to standard	IEC 60664-1, IEC 61984	Rated current, min. number of poles (Tu=20°C)	17.5 A
Rated current, max. number of poles (Tu=20°C)	13.9 A	Rated current, min. number of poles (Tu=40°C)	17 A
Rated current, max. number of poles (Tu=40°C)	12.4 A	Rated voltage for surge voltage class / pollution degree II/2	320 V
Rated voltage for surge voltage class / pollution degree III/2	160 V	Rated voltage for surge voltage class / pollution degree III/3	160 V
Rated impulse voltage for surge voltage class/ pollution degree II/2	2.5 kV	Rated impulse voltage for surge voltage class/ pollution degree III/2	2.5 kV
Rated impulse voltage for surge voltage class/ contamination degree III/3	2.5 kV	Short-time withstand current resistance	3 x 1s with 76 A

SC-SMT 3.81/03/90LF 3.2SN BK RL

Weidmüller Interface GmbH & Co. KG

Klingenbergstraße 26

D-32758 Detmold

Germany

www.weidmueller.com

Technical data

Rated data acc. to CSA

Institute (CSA)



Certificate No. (CSA)

200039-1121690

Rated voltage (Use group B / CSA) 300 V

Rated current (Use group B / CSA) 11 A

Reference to approval values

Specifications are maximum values, details - see approval certificate.

Rated data acc. to UL 1059

Institute (cURus)



Certificate No. (cURus)

E60693

Rated voltage (Use group B / UL 1059) 300 V

Rated voltage (Use group D / UL 1059) 300 V

Rated current (Use group B / UL 1059) 11 A

Rated current (Use group D / UL 1059) 11 A

Reference to approval values

Specifications are maximum values, details - see approval certificate.

Packing

Packaging	Tape	VPE length	50 mm
VPE width	330 mm	VPE height	330 mm
Tape depth (T2)	11.1 mm	Tape width (W)	44 mm
Tape pocket depth (K0)	10.6 mm	Tape pocket height (A0)	9.5 mm
Tape pocket width (B0)	22 mm	Tape pocket separation (P1)	16 mm
Tape hole separation (E)	1.75 mm	Tape pocket separation (F)	20.2 mm
Tape reel diameter \varnothing (A)	330 mm	Surface resistance	$R_s = 10^9 - 10^{12} \Omega$

Classifications

ETIM 6.0	EC002637	ETIM 7.0	EC002637
ECLASS 9.0	27-44-04-02	ECLASS 9.1	27-44-04-02
ECLASS 10.0	27-44-04-02	ECLASS 11.0	27-46-02-01

Important note

IPC conformity

Conformity: The products are developed, manufactured and delivered according international recognized standards and norms and comply with the assured properties in the data sheet resp. fulfill decorative properties in accordance with IPC-A-610 "Class 2". Further claims on the products can be evaluated on request.

Notes

- Rated current related to rated cross-section & min. No. of poles.
- Rated data refer only to the component itself. Clearance and creepage distances to other components are to be designed in accordance with the relevant application standards.
- P on drawing = pitch
- Long term storage of the product with average temperature of 50 °C and average humidity 70%, 36 months

Data sheet**SC-SMT 3.81/03/90LF 3.2SN BK RL****Weidmüller Interface GmbH & Co. KG**
Klingenbergstraße 26
D-32758 Detmold
Germany

www.weidmueller.com

Technical data**Approvals**

Approvals

ROHS Conform
UL File Number Search E60693**Downloads**Approval/Certificate/Document of Conformity [Declaration of the Manufacturer](#)
Engineering Data [STEP](#)
Product Change Notification [Standardization of M2.5 square nut -DE](#)
[Standardization of M2.5 square nut -EN](#)

Data sheet

SC-SMT 3.81/03/90LF 3.2SN BK RL

Weidmüller Interface GmbH & Co. KG
 Klingenbergstraße 26
 D-32758 Detmold
 Germany

www.weidmueller.com

Drawings

Dimensional drawing

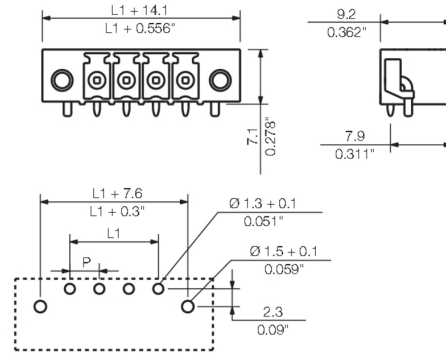

Example of use



Dimensional drawing

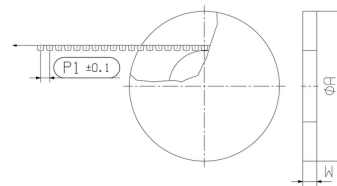

Dimensional drawing

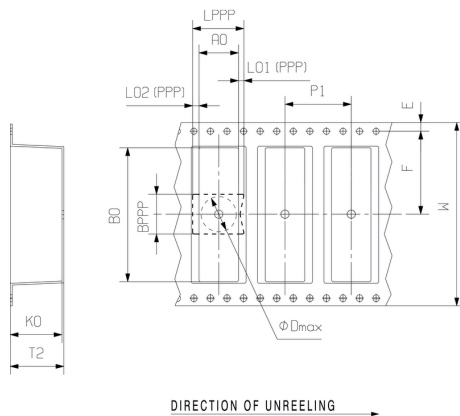

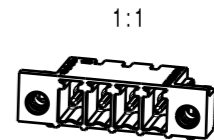
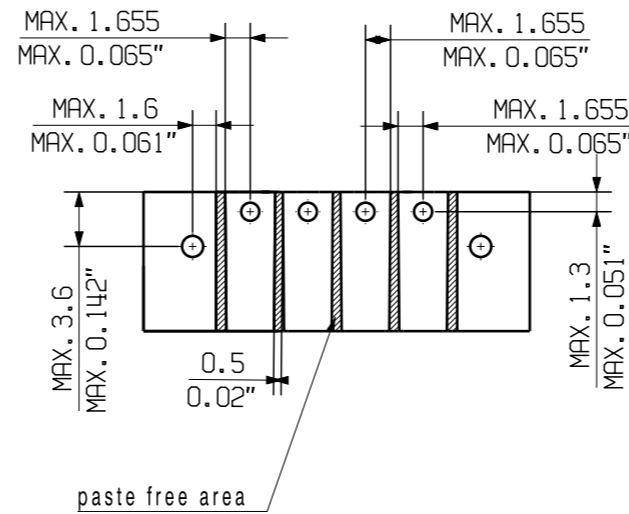
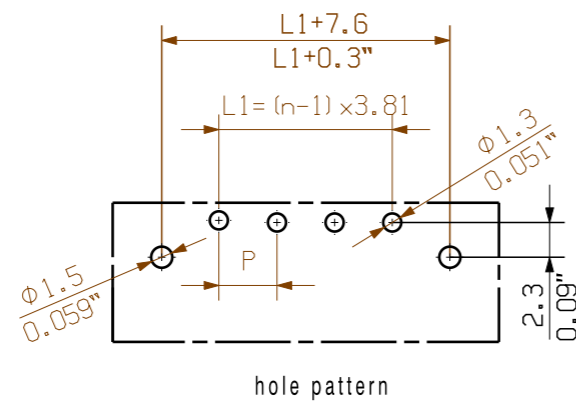
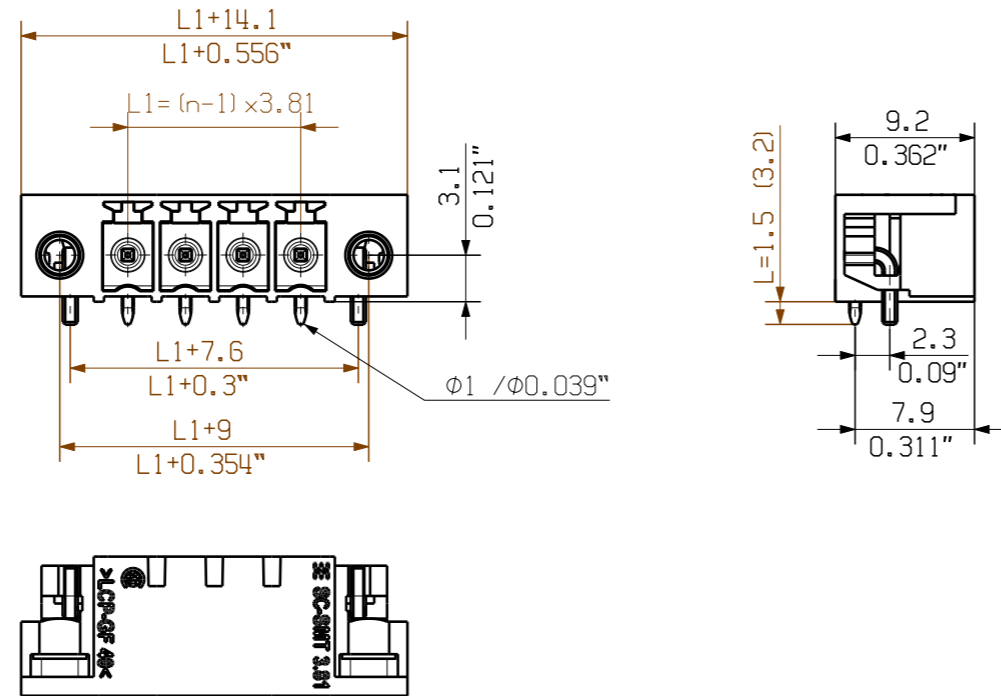

16	57,15	2,252
15	53,34	2,102
14	49,53	1,951
13	45,72	1,801
12	41,91	1,651
11	38,1	1,501
10	34,29	1,351
9	30,48	1,201
8	26,67	1,051
7	22,86	0,901
6	19,05	0,751
5	15,24	0,600
4	11,43	0,450
3	7,62	0,300
2	3,81	0,150
n	L1 [mm]	L1 [Inch]

pin length l	tolerance	Cat.no.:	
		1,5	0,0 -0,2
3,2	0,0 -0,2	4 3	11,43 7,62
2,1	0,1 -0,2	2 n	3,81 L1 [mm]

P= Raster/pitch
n= Polzahl/no of poles
shown: SC-SMT3.81/04/90LF

For the mounting of PCBs, it should be noted that the rated data relates only to the PCB components alone.
The necessary creepage and clearance paths must be observed in connection with the respective applicant in accordance to IEC 664 / VDE 0110.
The current-carrying capacity and pitch tolerance is to be determined according to DIN IEC 326 part 3 very fine.

Weidmüller PCB components are tested to the DIN EN 61984 standard, and are valid for its field of application.
Provided that the components are used to the intended purpose, all requirements with respect to the occurring of electrical, mechanical, thermic and corrosive stress will be satisfied.

GENERAL TOLERANCE:
DIN ISO 2768-m



Scale: 5:1
Supersedes: .

106980/5 02.08.18 HELIS_MA 00	00	Modification	
Drawn	11.11.2004	POCTA_C	
Responsible		AMANN_A	
Checked	29.08.2018	HELIS_MA	
Approved		LANG_T	

Weidmüller

Cat.no.:

3 36136

Drawing no. Issue no.
Sheet 03 of 05 sheets

SC-SMT 3.81/02...16/90...
STIFTLISTE
MALE HEADER

Product file: SC-SMT 3.81

7278

Recommended wave soldering profiles

Weidmüller Interface GmbH & Co. KG
 Klängenbergstraße 16
 D-32758 Detmold
 Germany
 Fon: +49 5231 14-0
 Fax: +49 5231 14-292083
 www.weidmueller.com

Single Wave:



Double Wave:



Wave soldering profiles

Wired connection elements should be processed in accordance with the DIN EN 61760-1 standard. We have included two recommendations for practical wave soldering profiles, with which Weidmüller PCB terminals and connectors are qualified.

When choosing a suitable profile for your application, the following factors also need to be considered:

- PCB thickness
- Proportion of Cu in the layers
- Single/double-sided assembly
- Product range
- Heating and cooling rates

The single and double wave profiles each indicate the recommended operating range, including the maximum soldering temperature of 260°C. In practice, the maximum soldering temperature is quite often well below the above maximum profile.

Recommended reflow soldering profile

Weidmüller Interface GmbH & Co. KG
 Klingenbergstraße 16
 D-32758 Detmold
 Germany
 Fon: +49 5231 14-0
 Fax: +49 5231 14-292083
 www.weidmueller.com



Reflow soldering profile

The perfect soldering profile for SMT Surface Mount Technology is one the most exiting question in SMT production. But there are more than one correct answer: The diagram of temperature-on-time is related to processing features of solder paste and to maximum load of components.

We have to consider the following parameters:

- Time for pre heating
- Maximum temperature
- Time above melting point
- Time for cooling
- Maximum heating rate
- Maximum cooling rate

We recommend a typical solder profile with associated process limits. With preheating components and board are prepared smoothly for the solder phase. Heating rate is typically $\leq +3\text{K/s}$. In parallel the solder paste is ‚activated‘. The time above melting point of 217°C the paste gets liquid and components and boards begin to connect. The maximum temperature of 245°C to 254°C should stay between 10 and 40 seconds. In the cooling phase at $\geq -6\text{K/s}$ solder is cured. Board and components cool down while avoiding cold cracks.