

Data sheet for three-phase Squirrel-Cage-Motors SIMOTICS

Motor type: GP100A **FS: 145T - 4p - 1.5 hp -**

Client order no.	Item-No.	Offer no.
Order no.	Consignment no.	Project

Remarks

Electrical data without

U [V]	Δ/Y	f [Hz]	P [HP]	P [kW]	n [rpm]	I Load [Amps]					LRC	Nom. Eff Load [%]			Pwr. Factor Load [%]			Torque [lb-ft]	T _A /T _N LRT [%]	T _k /T _N BDT [%]
						4/4	3/4	1/2	0	4/4		3/4	2/4	4/4	3/4	2/4				
460	Y	60	1.50	1.00	1,740	2.10	1.70	1.40	1.10	19.0	86.5	87.0	85.8	77.3	71.8	58.5	4.5	333	422	
230	YY	60	1.50	1.00	1,740	4.20	3.37	2.80	2.20	38.0	86.5	87.0	85.8	77.3	71.8	58.5	4.5	333	422	

Frame Type: 145T	Type of constr.: (E) Foot mounted - C-Face	Ins. Cl.: Standard Class F Insulation	Motor Prot.: (A) Without Protection	NEMA Des.: B	S.F.: 1.15
Mtr. WT:49		Temp. Rise Cl.: B	Amb. Temp.: + 40 to -20 °C @1000 m	kVA: M	I.P.: 55

Mechanical data

Sound level (SPL / SWL) at 60 Hz	50.0 dB(A) / 62.0 dB(A)		Thickener	Polyurea					
Octave Band Center Frequencies Hertz			Safe Stall Time Hot	15 s					
	250	500	1000	2000	4000	8000	Hz	Safe Stall Time Cold	21 s
SPL@3	37.0	40.0	49.0	45.0	37.0	31.0	dB(A)	Frame material	aluminum
Moment of inertia	0.2 Lb-ft ²		Color, paint shade	Standard Paint - RAL7030					
Ext Load Inertia Capability:	86.0 Lb ft ²		Coating (paint finish)	Standard Alkyed + Epoxy (C2)					
Bearings			Ventilation Type						
Bearing DE NDE	6205 ZZ C3 S0		6205 ZZ C3 S0						
Bearing_Type	Ball Bearing		Ball Bearing						
AFBMA:	25BC02JPP30		25BC02JPP30						
Grease			Method of cooling	TEFC					
Capacity	0.10 oz		0.10 oz						
Grease Type:	Exxon Mobile EM		Direction of rotation	Bidirectional					
			Fan Material	Polypropylen					
			VFD	CT: 4:1 VT: 20:1					
			Space heaters	without					
			Brake:	without					

Terminal box

Lead Wire Connection	9 LEAD - WYE				Terminal box position	(3) F-1, Standard Floor Mount, T. Box LHS
Voltage	L1	L1	L1	Connected together	Material of terminal box	Aluminium
LOW	T1 T7	T2 T8	T3 T9	T4 T5 T6	Cable entry	.75" NPT
HIGH	T1	T2	T3	T4 T7-T5 T8-T6 T9		

Notes:

I_r/I_N = locked rotor current / current nominal
M_r/M_N = locked rotor torque / torque nominal
M_d/M_N = break down torque / nominal torque

3) Value is valid only for DOL operation with motor design IC411
2) at rated power / at full load

responsible dep. DI MC LVM	technical reference	created by DT Configurator	approved by	<i>Technical data are subject to change! There may be discrepancies between software and hardware versions.</i>
-------------------------------	---------------------	-------------------------------	-------------	---

	document type datasheet	document status released	customer	
	title 1LE2121-1AB31-4EA3	document number		
© Siemens AG 2021	rev. 01	creation date 2021-04-22 08:27	language en	Page 1/1

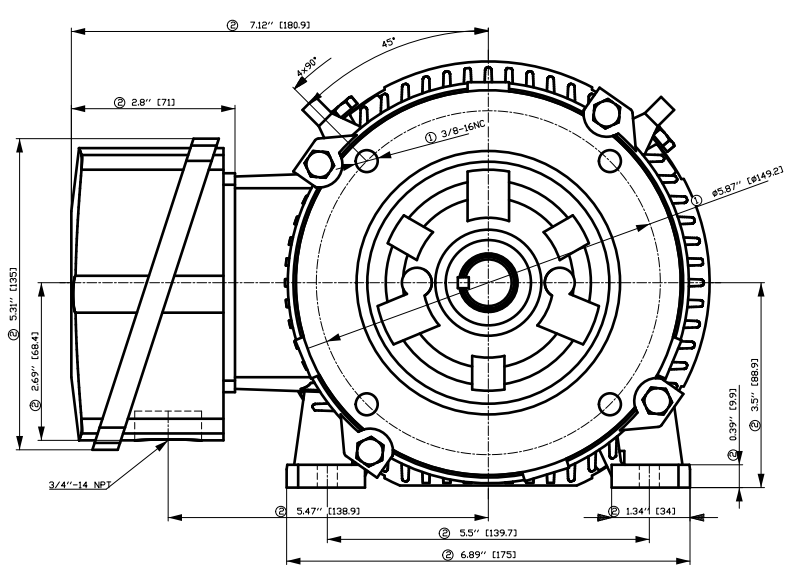

- ① Tolerances according to NEMA std.
- ② All these dimensions corresponding to assemblies and castings shall have a tolerance as per DIN standard 1686-GTB 19.
- ③ Not according to NEMA std.

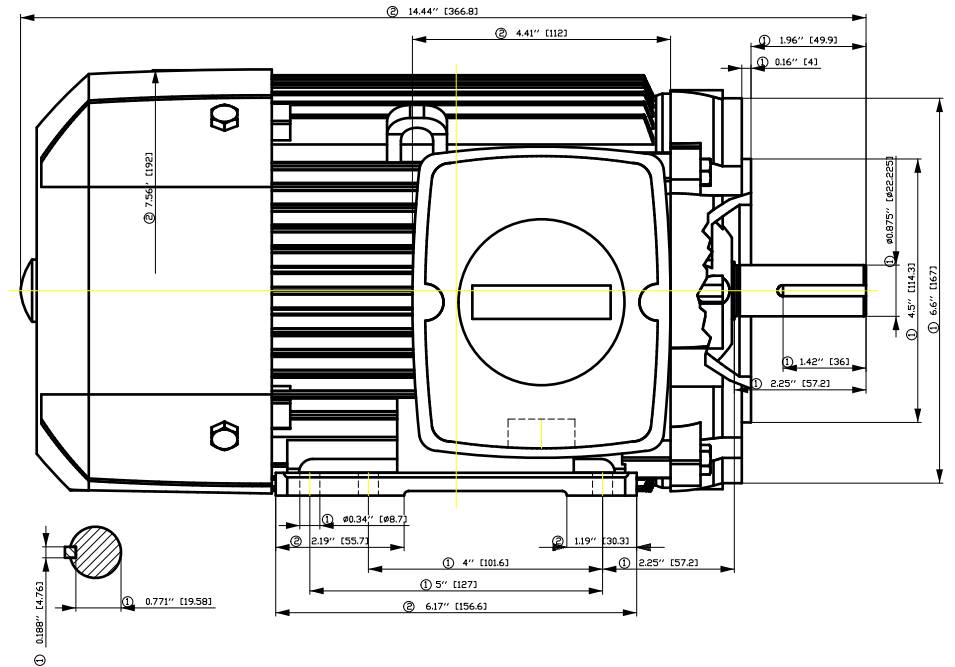

Tolerance	Surface	Material	Weight	Scale	
F5ÖGFGFËÖCHË ÖCH	Author	Öv ^}•} }ç/ç} } *	E		
E	Creator				ÖVS
	Approval				T æ : ^æ@` } *
	Department				
	Change Order	MLFB	Doc Type	/	
	Doc. State	1 B030F	Item No	Paper Size	
	Revision	Index	Doc No	1st Language	
				2nd Language	
© Siemens AG	Project No	E	Ref No	E	
2018				Sheet	
				F of F	

刀线管... 用转为... 文... 金... 路... 的... 积...
 01... 02... 03... 04... 05... 06... 07... 08... 09... 10... 11... 12... 13... 14... 15... 16... 17... 18... 19... 20... 21... 22... 23... 24... 25... 26... 27... 28... 29... 30... 31... 32... 33... 34... 35... 36... 37... 38... 39... 40... 41... 42... 43... 44... 45... 46... 47... 48... 49... 50... 51... 52... 53... 54... 55... 56... 57... 58... 59... 60... 61... 62... 63... 64... 65... 66... 67... 68... 69... 70... 71... 72... 73... 74... 75... 76... 77... 78... 79... 80... 81... 82... 83... 84... 85... 86... 87... 88... 89... 90... 91... 92... 93... 94... 95... 96... 97... 98... 99... 100...

SIEMENS INDUSTRY, INC.

HP 1,5 VOLTS < 600V RPM 1800 TYPE GP100A
HZ 60 PHASE 3 FRAME 145T NEMA B

TORQUE & CURRENT VS. SPEED

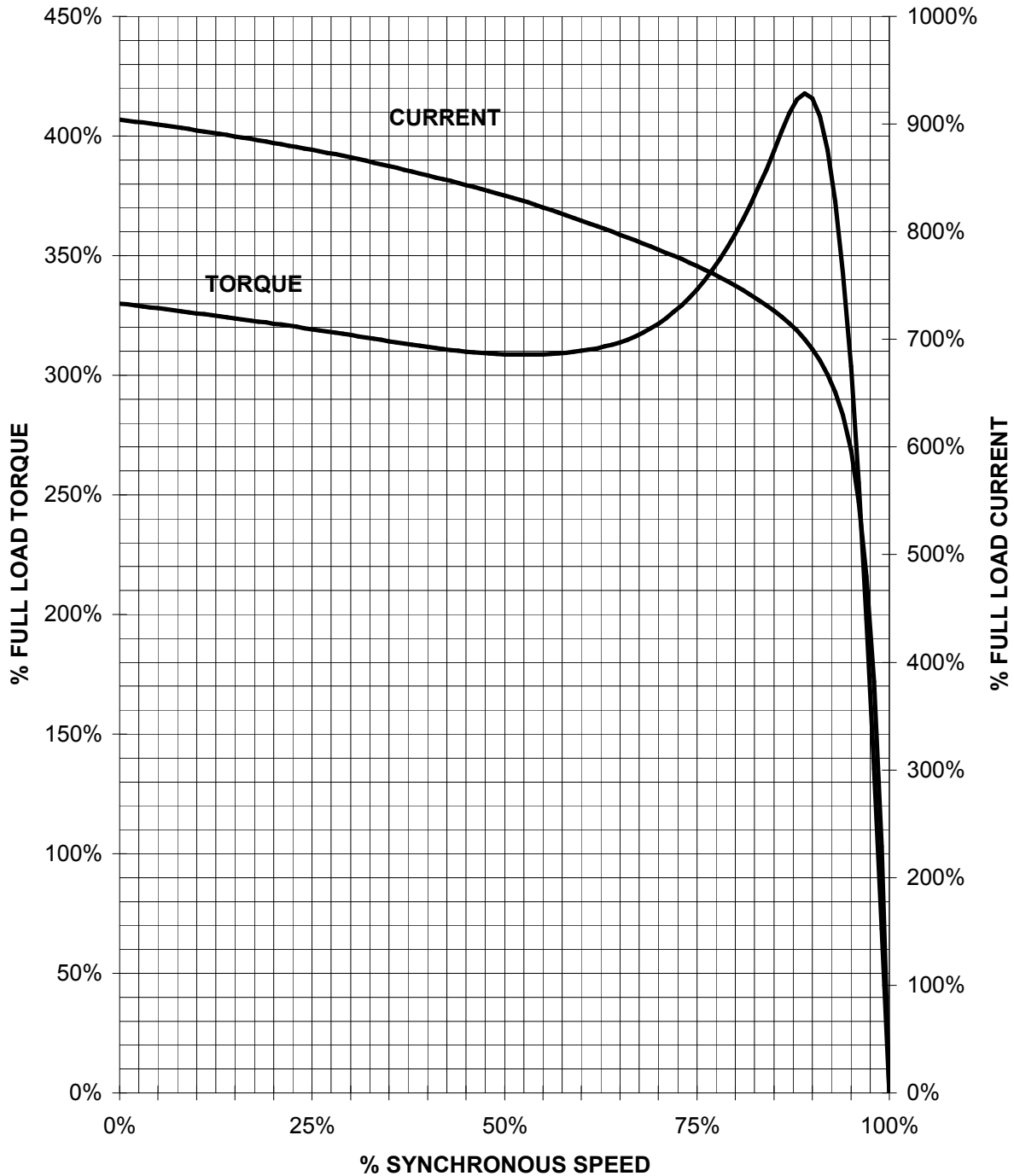

CUSTOMER: _____ ORDER#: _____

1.5 HP 1800 RPM 145 FRAME 460 VOLTS 3 PHASE NEMA DESIGN B

SIEMENS INDUSTRY, INC.
PERFORMANCE CURVE
GP100A NP

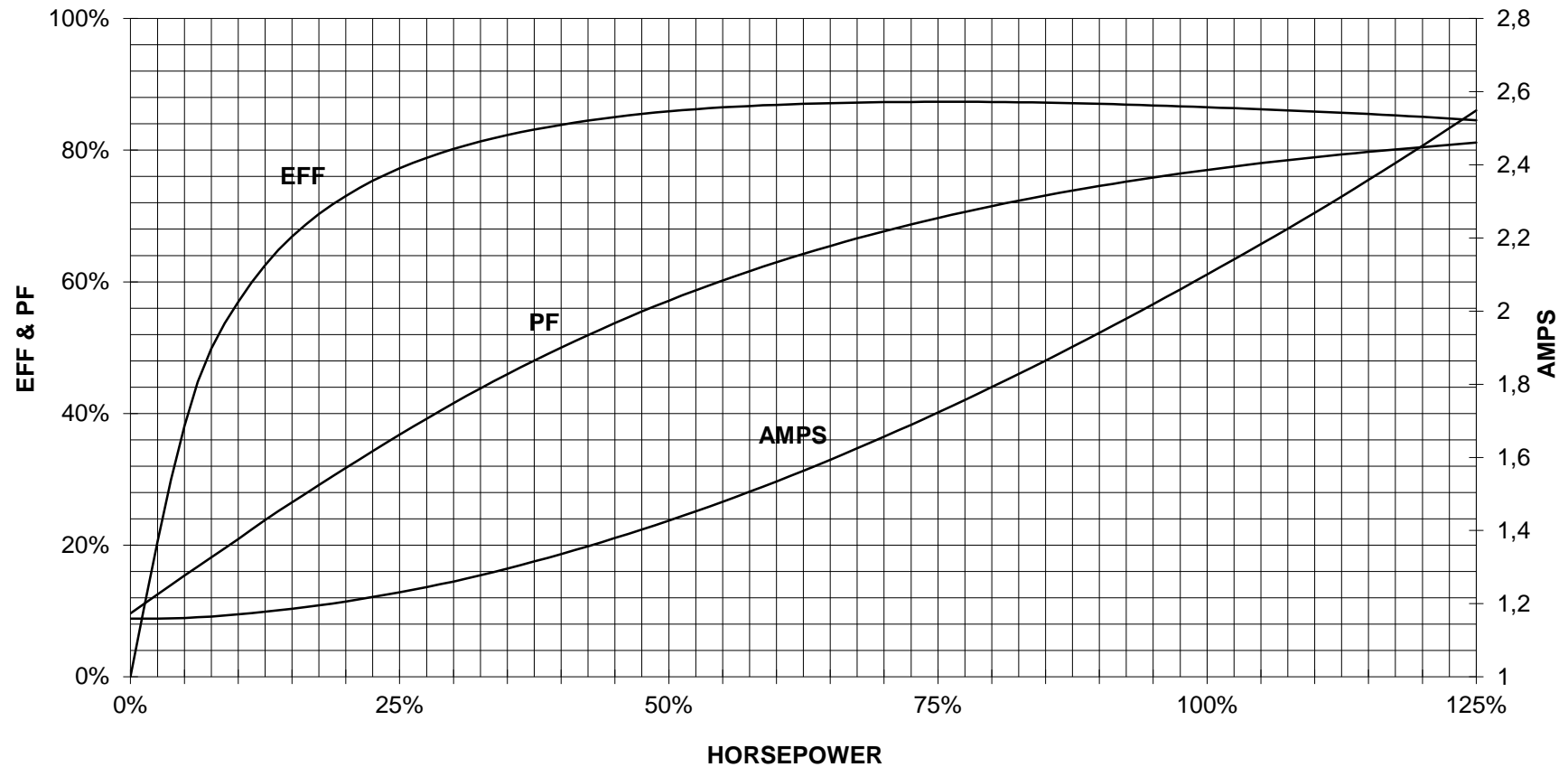

CUSTOMER _____ ORDER # _____ PO # _____

PERFORMANCE BASED ON DESIGN CALCULATIONS. SUBJECT TO CHANGE WITHOUT NOTICE.

REV. 1

Main terminal diagram

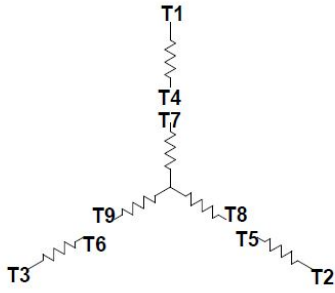

9 LEAD WYE						
Volts	LINES			CONNECTED TOGETHER	CONN.	
	L1	L2	L3			
LOW	T1 T7	T2 T6	T3 T9	T4 T5 T6	YY	
HIGH	T1	T2	T3	T4 T7-T5 T8-T6 T9	Y	

responsible dep. DI MC LVM	technical reference	created by	approved by	Project
SIEMENS	document type Wiring Diagram	document status free		customer
	title 1LE2121-1AB31-4EA3	document number		
© Siemens AG 2019	rev. 01	creation date 12/03/2019	language en	Page 1/1