

# Data sheet for three-phase Squirrel-Cage-Motors SIMOTICS

Motor type: **GP100** FS: **182T - 2p - 3 hp -**

Client order no.	Item-No.	Offer no.
Order no.	Consignment no.	Project

Remarks

## Electrical data without

U [V]	$\Delta/Y$	f [Hz]	P [HP]	P [kW]	n [rpm]	I Load [Amps]					LRC	Nom. Eff Load [%]			Pwr. Factor Load [%]			Torque [lb-ft]	T <sub>A</sub> /T <sub>N</sub> LRT [%]	T <sub>k</sub> /T <sub>N</sub> BDT [%]
						4/4	3/4	1/2	0	4/4		3/4	2/4	4/4	3/4	2/4				
460	Y	60	3.00	2.00	3,520	3.80	3.10	2.40	1.70	30.0	86.5	86.3	84.2	85.5	79.8	69.5	4.4	186	386	
230	YY	60	3.00	2.00	3,520	7.60	6.12	4.80	3.40	60.0	86.5	86.3	84.2	85.5	79.8	69.5	4.4	186	386	

Frame Type: 182T	Type of constr.: ( G ) Round body - C-Face	Ins. Cl.: Standard Class F Insulation	Motor Prot.: (A) Without Protection	NEMA Des.: B	S.F.: 1.15
Mtr. WT: 81		Temp. Rise Cl.: B	Amb. Temp.: + 40 to -20 °C @1000 m	kVA: J	I.P.: 55

## Mechanical data

Sound level (SPL / SWL) at 60 Hz	69.0 dB(A) / 81.0 dB(A)		Thickener	Polyurea					
Octave Band Center Frequencies Hertz			Safe Stall Time Hot	20 s					
	250	500	1000	2000	4000	8000	Hz	Safe Stall Time Cold	30 s
SPL@3	49.0	61.0	66.0	64.0	60.0	50.0	dB(A)	Frame material	cast iron
Moment of inertia	0.1 Lb-ft <sup>2</sup>		Color, paint shade	Standard Paint - RAL7030					
Ext Load Inertia Capability:	35.0 Lb ft <sup>2</sup>		Coating (paint finish)	Standard Alkyed + Epoxy (C2)					
<b>Bearings</b>									
Bearing DE   NDE	6206 ZZ C3 S0		6206 ZZ C3 S0						
Bearing_Type	Ball Bearing		Ball Bearing						
AFBMA:	30BC02JPP30		30BC02JPP30						
<b>Grease</b>									
Capacity	0.20 oz		0.20 oz						
Grease Type:	Exxon Mobile EM								
<b>Ventilation Type</b>									
Method of cooling			TEFC						
Direction of rotation			Bidirectional						
Fan Material			Polypropylen						
VFD			CT: 4:1 VT: 20:1						
Space heaters			without						
Brake:			without						

## Terminal box

Lead Wire Connection	9 LEAD - WYE				Terminal box position	(3) F-1, Standard Floor Mount, T. Box LHS
Voltage	L1	L1	L1	Connected together	Material of terminal box	Aluminium
LOW	T1 T7	T2 T8	T3 T9	T4 T5 T6	Cable entry	.75" NPT
HIGH	T1	T2	T3	T4 T7-T5 T8-T6 T9		

## Notes:

I<sub>r</sub>/I<sub>N</sub> = locked rotor current / current nominal  
M<sub>r</sub>/M<sub>N</sub> = locked rotor torque / torque nominal  
M<sub>d</sub>/M<sub>N</sub> = break down torque / nominal torque

3) Value is valid only for DOL operation with motor design IC411  
2) at rated power / at full load

responsible dep. DI MC LVM	technical reference	created by DT Configurator	approved by	<i>Technical data are subject to change! There may be discrepancies between our website and our data sheets.</i>
-------------------------------	---------------------	-------------------------------	-------------	--

	document type datasheet	document status released	customer	
	title 1LE2221-1CA11-4GA3-Z 809	document number	rev. 01	creation date 2021-04-21 12:26
© Siemens AG 2021				Page 1/2

**Data sheet for three-phase Squirrel-Cage-Motors SIMOTICS**

Motor type: GP100 FS: 182T - 2p - 3 hp -

**Special design**

B09	Export packing sea freight - Siemens standard

**Notes:**

responsible dep. DI MC LVM	technical reference	created by DT Configurator	approved by	<i>Technical data are subject to change! There may be discrepancies between software and hardware output</i>
	document type datasheet	document status released		customer
	title 1LE2221-1CA11-4GA3-Z B09	document number		
© Siemens AG 2021	rev. 01	creation date 2021-04-21 12:26	language en	Page 2/2

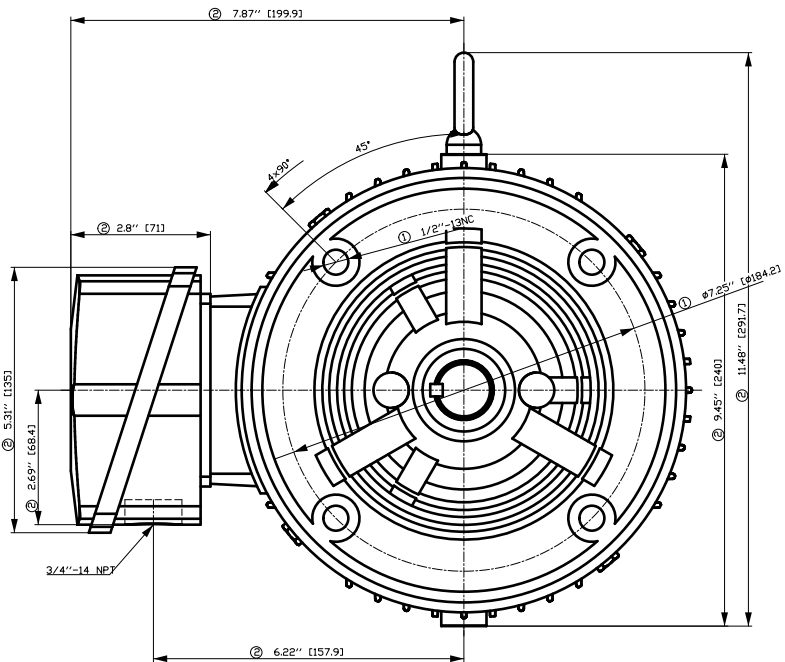

- ① Tolerances according to NEMA std.
- ② All these dimensions corresponding to assemblies and castings shall have a tolerance as per DIN standard 1686-GTB 19.
- ③ Not according to NEMA std.

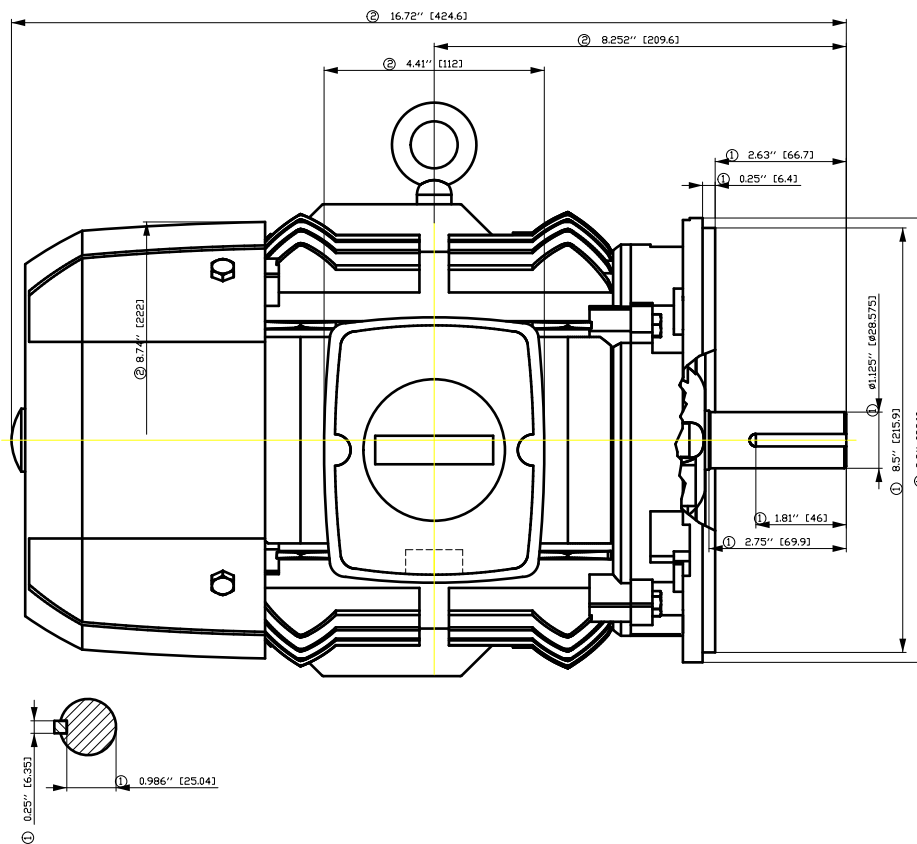

Tolerance	Surface	Material	Weight	Scale
F50GG3F-Ö0CFB Ö0CFZ Ö0EJ	Author Creator Approval Department Change Order	Ö0E J } • } } } } } } } T a : ^ & @ } } *	E	{ {
SIEMENS	Doc. State	Item No	Doc Type	Paper Size
	Revision	Index	RS	1st Language
	Doc No	Doc No	2nd Language	â^
	Project No	E	Ref No	E
© Siemens AG 2018	Project No	E	Ref No	E
				Sheet F of F

# SIEMENS INDUSTRY, INC.

HP 3 VOLTS < 600V RPM 3600 TYPE GP100  
HZ 60 PHASE 3 FRAME 182T NEMA B

## TORQUE & CURRENT VS. SPEED

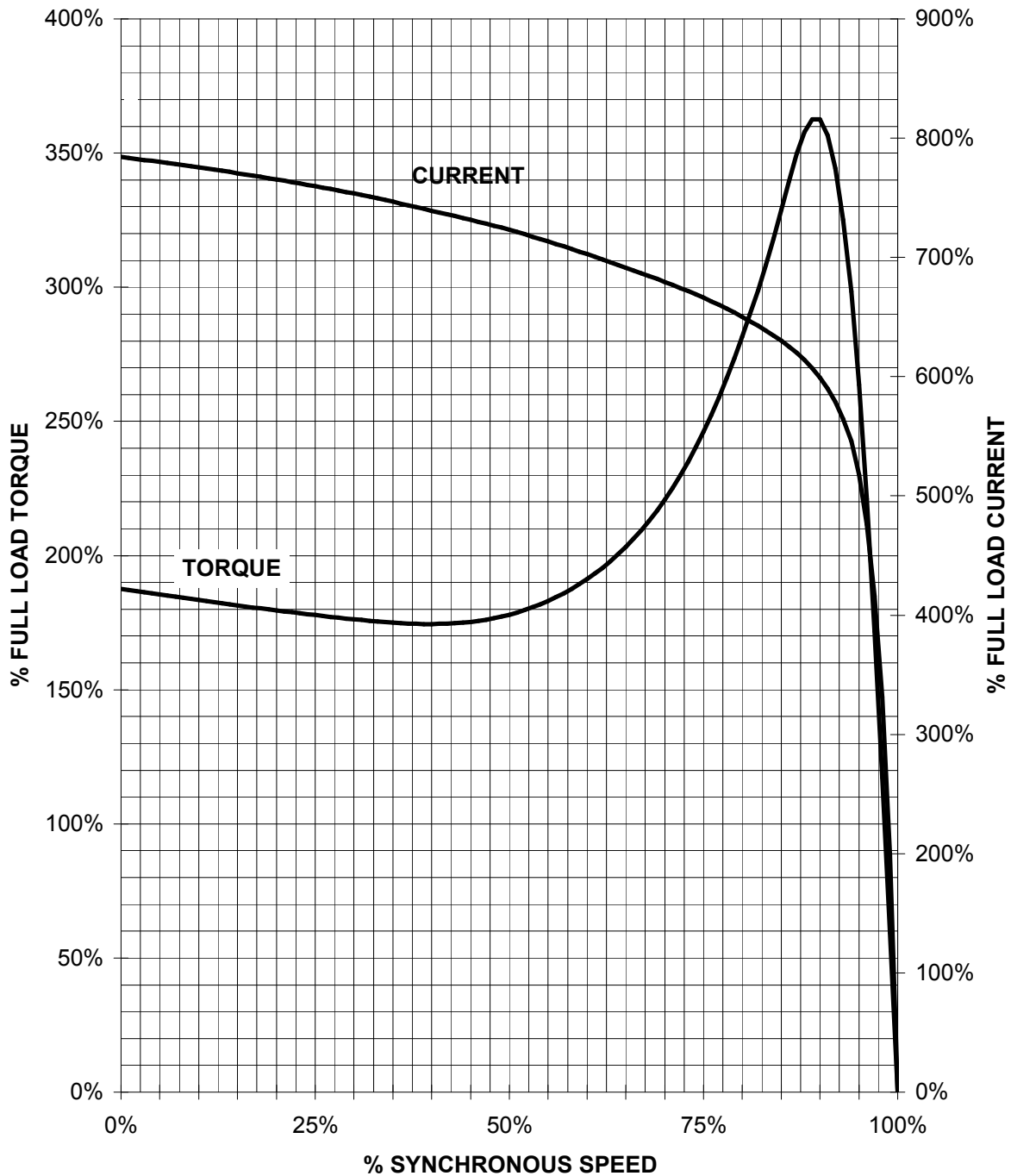

CUSTOMER: \_\_\_\_\_ ORDER#: \_\_\_\_\_

3 HP 3600 RPM 182T FRAME 460 VOLTS 3 PHASE NEMA DESIGN B

**SIEMENS INDUSTRY, INC.**  
**PERFORMANCE CURVE**  
**GP100**

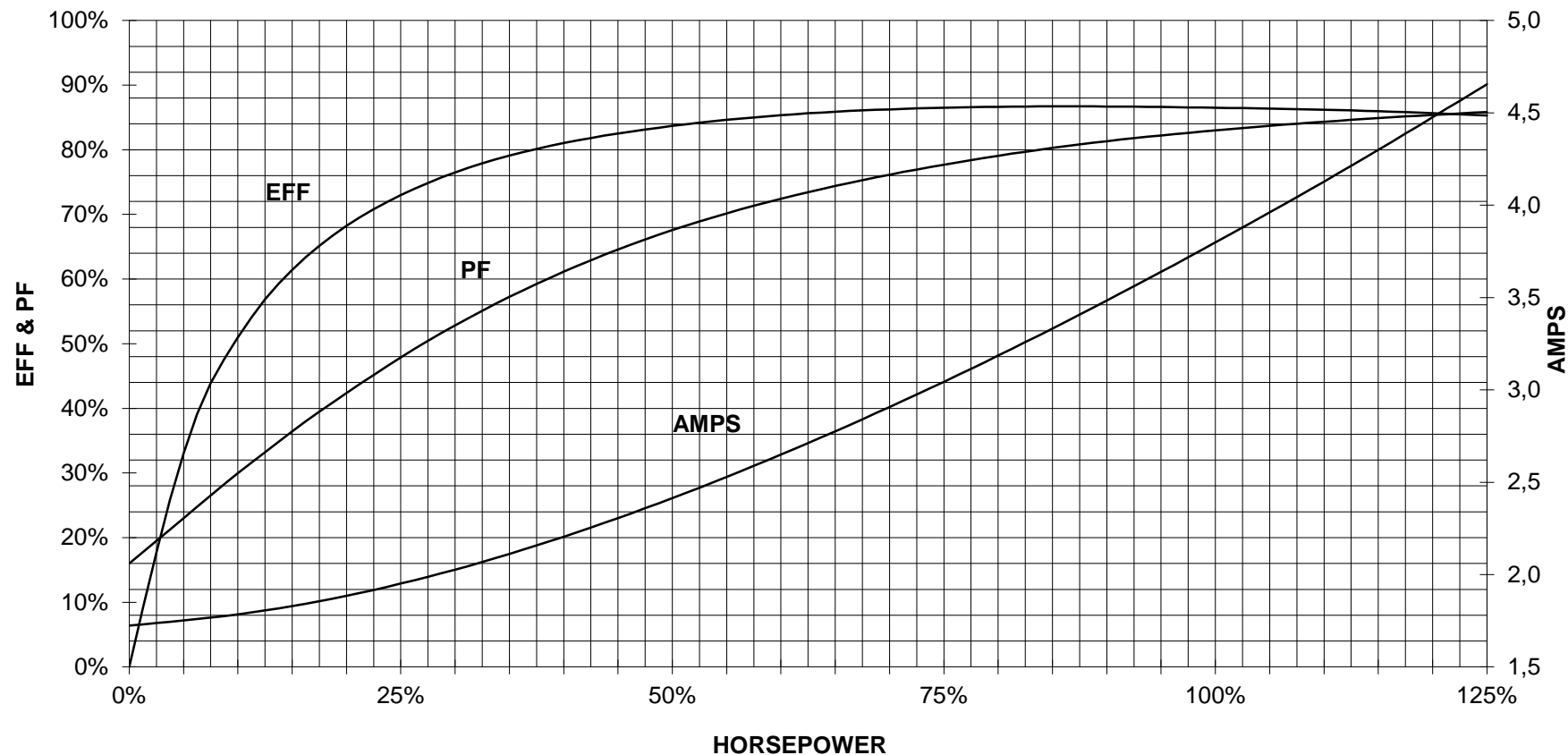

CUSTOMER \_\_\_\_\_ ORDER # \_\_\_\_\_ PO # \_\_\_\_\_

PERFORMANCE BASED ON DESIGN CALCULATIONS. SUBJECT TO CHANGE WITHOUT NOTICE.

REV. 1

Main terminal diagram

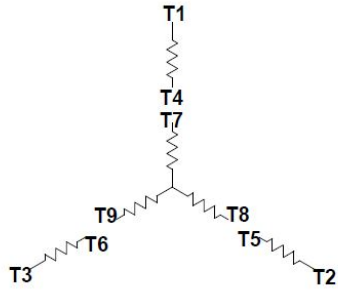

9 LEAD WYE						
Volts	LINES			CONNECTED TOGETHER	CONN.	
	L1	L2	L3			
LOW	T1 T7	T2 T6	T3 T9	T4 T5 T6	YY	
HIGH	T1	T2	T3	T4 T7-T5 T8-T6 T9	Y	

responsible dep. DI MC LVM	technical reference	created by	approved by	Project
<b>SIEMENS</b>	document type Wiring Diagram	document status free		customer
	title 1LE2221-1CA11-4GA3-Z 809	document number		
© Siemens AG 2019	rev. 01	creation date 12/03/2019	language en	Page 1/1