

PT160R-13-LI3-H1131

Pressure Transmitter – With Current Output (2-Wire)

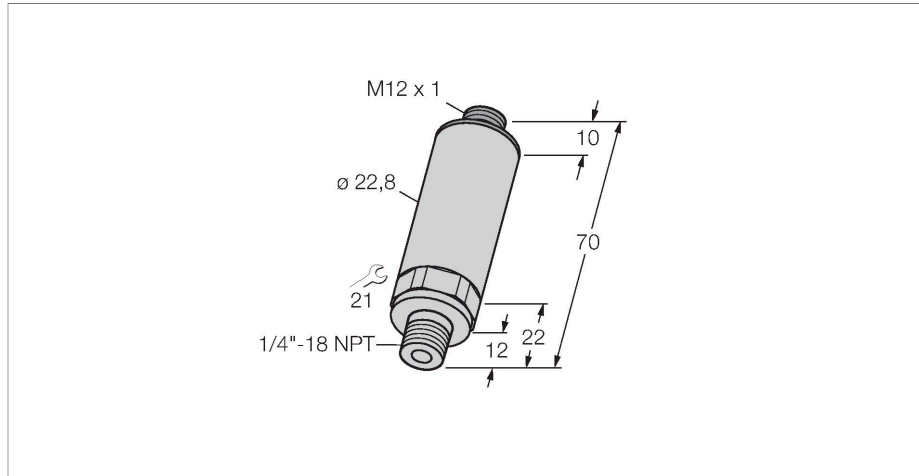

Features

- Compact and robust design
- Pressure connection with integrated peak pressure aperture
- Accuracy hardly affected by temperature within entire range -40...+125°C
- Excellent EMC properties
- Pressure range 0...160 bar rel.

Wiring diagram

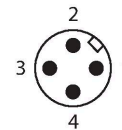
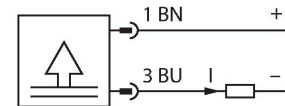

Technical data

Type	PT160R-13-LI3-H1131
Ident. no.	6831508
Pressure range	
Relative pressure bar	0...160 bar rel.
	0...2320.6 psi
	0...16 MPa
Admissible overpressure	≤ 400 bar
Burst pressure	≥ 400 bar
Response time	< 2 ms, typ. 1 ms
Long-term stability	1 % FS, In accordance with DIN EN 60770
Power supply	
Operating voltage	8...33 VDC
Current consumption	≤ 20 mA
Protective measure	SELV according to EN 50178
Short-circuit/reverse polarity protection	yes / yes
Protection type and class	IP67 / III
Insulation voltage	500 VDC
Outputs	
Output 1	Analog output
Output function	Analog output current
Analog output	
Current output	4...20 mA

Functional principle

The pressure transmitters of the PT...-1 series operate with piezo-resistive ceramic measuring cells. The ceramic diaphragm is unbalanced in proportion to the pressure applied. Depending on the sensor type used, the processed signal is provided as an analog output signal 4...20mA (2-wire) or 0...10V (3-wire).

Technical data

Load	≤ 1 kΩ
Accuracy LHR	± 0.3 % FS BSL
Calibration accuracy 0-point	0.3 % FS
Calibration accuracy full scale	0.3 % FS
Temperature behaviour	
Medium temperature	-40...+125 °C
Temperature coefficient zero point T _{k0}	± 0.15 % of full scale/10 K
Temperature coefficient span T _{ks}	± 0.15 % of full scale/10 K
Ambient conditions	
Ambient temperature	-40...+85 °C
Storage temperature	-40...+85 °C
Vibration resistance	20 x g (9...2000 Hz, 2...9 Hz with an amplitude +/-15 mm), acc. to IEC 68-2-6
Shock resistance	100 g (11 ms) , acc. to IEC 68-2-27
Housing	
Housing material	Stainless-steel/Plastic, 1.4305 (AISI 303)
Pressure connection material	Stainless steel 1.4305 (AISI 303)
Pressure transducer material	Ceramics Al ₂ O ₃
Sealing material	FPM
Process connection	1/4" NPT-18 male thread
Wrench size pressure connection / coupling nut	SW 21
Electrical connection	Connector, M12 × 1
Max. tightening torque of housing nut	20 Nm
Reference conditions acc. to IEC 61298-1	
Temperature	15...+25 °C
Atmospheric pressure	860...1060 hPa abs.
Humidity	45...75 % rel.
Auxiliary power	24 VDC
MTTF	760 years acc. to SN 29500 (Ed. 99) 40 °C