



ADAPT-PB-MLG

SICK
Sensor Intelligence.



Ordering information

Type	Part no.
ADAPT-PB-MLG	1027921

Other models and accessories → www.sick.com/

Detailed technical data

Classifications

ECl@ss 5.0	27279202
ECl@ss 5.1.4	27279202
ECl@ss 6.0	27279202
ECl@ss 6.2	27279202
ECl@ss 7.0	27279202
ECl@ss 8.0	27279202
ECl@ss 8.1	27279202
ECl@ss 9.0	27273701
ECl@ss 10.0	27273701
ECl@ss 11.0	27273701
ETIM 5.0	EC001020
ETIM 6.0	EC001020
UNSPSC 16.0901	31163032

Technical specifications

Accessory family	Bus adapter
Connection type head A	Female connector, M12, 8-pin, straight
Signal type	PROFIBUS DP
Connecting cable	0.3 m, PUR
Cable material	PUR
Conductor cross-section	0.32 mm ²
Note	PROFIBUS-DP adapter cable (PROFIBUS IN, PROFIBUS OUT, and voltage supply), suitable for drag chain

Dimensional drawing (Dimensions in mm (inch))

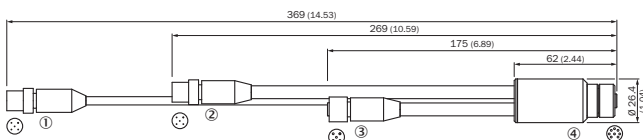

- ① MLG connection
- ② PROFIBUS OUT M12, 5-pin
- ③ PROFIBUS IN M12, 5-pin
- ④ MLG receiver

Connection type

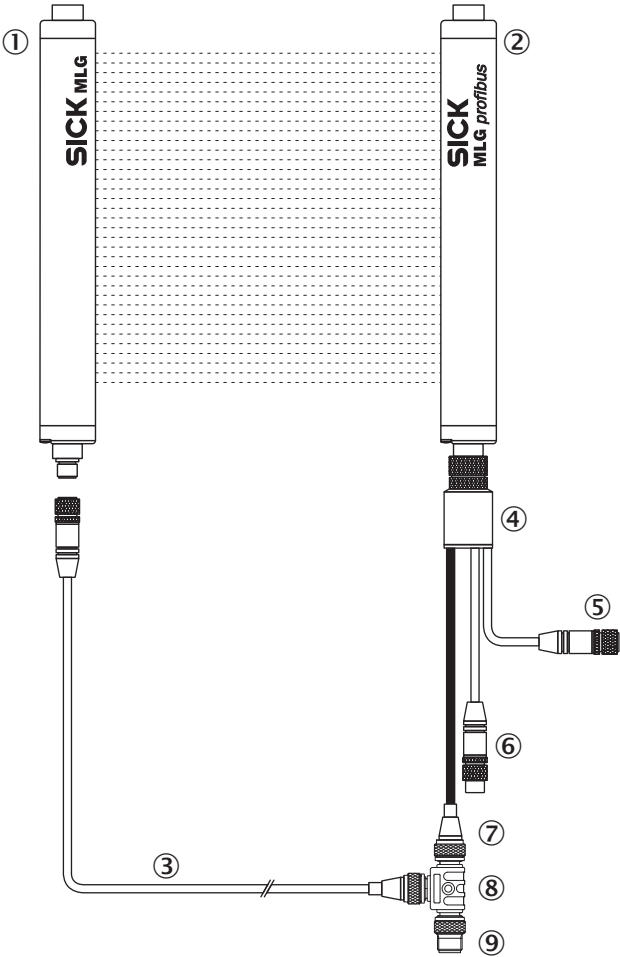

- ① MLG sender
- ② MLG receiver
- ③ Connection cable
- ④ PROFIBUS adapter straight
- ⑤ PROFIBUS IN M12, 5-pin
- ⑥ PROFIBUS OUT M12, 5-pin
- ⑦ MLG connection
- ⑧ Supply Q1

Anschlussschema

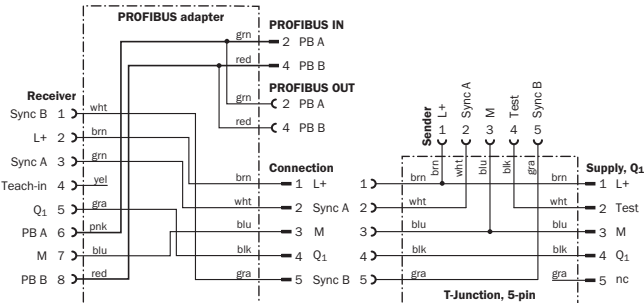

SICK AT A GLANCE

SICK is one of the leading manufacturers of intelligent sensors and sensor solutions for industrial applications. A unique range of products and services creates the perfect basis for controlling processes securely and efficiently, protecting individuals from accidents and preventing damage to the environment.

We have extensive experience in a wide range of industries and understand their processes and requirements. With intelligent sensors, we can deliver exactly what our customers need. In application centers in Europe, Asia and North America, system solutions are tested and optimized in accordance with customer specifications. All this makes us a reliable supplier and development partner.

Comprehensive services complete our offering: SICK LifeTime Services provide support throughout the machine life cycle and ensure safety and productivity.

For us, that is “Sensor Intelligence.”

WORLDWIDE PRESENCE:

Contacts and other locations –www.sick.com