

DFS60E-TGEA00S08

DFS60

INCREMENTAL ENCODERS

SICK
Sensor Intelligence.

Illustration may differ

Ordering information

| Type | Part no. |
|------------------|----------|
| DFS60E-TGEA00S08 | 1068237 |

Other models and accessories → www.sick.com/DFS60



Detailed technical data

Features

| | |
|----------------------------------|---|
| Special device | ✓ |
| Specialty | Customized stator coupling (2047428) premounted |
| Standard reference device | DFS60E-TGEA01024, 1037732 |

Performance

| | |
|---|------------------------------------|
| Pulses per revolution | 1,024 ¹⁾ |
| Measuring step | 90° electric/pulses per revolution |
| Measuring step deviation at binary number of lines | ± 0.15° |
| Error limits | ± 0.3° |

¹⁾ See maximum revolution range.

Interfaces

| | |
|--|------------------------|
| Communication interface | Incremental |
| Communication Interface detail | HTL / Push pull |
| Number of signal channels | 6-channel |
| Initialization time | 40 ms |
| Output frequency | ≤ 300 kHz |
| Load current | ≤ 30 mA |
| Power consumption | ≤ 0.5 W (without load) |
| 4.5 V... 5.5 V, TTL/RS-422 | |
| Load current | ≤ 30 mA |
| 4.5 V ... 5.5 V, Open Collector | |
| Load current | ≤ 30 mA |
| TTL/RS-422 | |
| Load current | ≤ 30 mA |
| Power consumption | ≤ 0.5 W (without load) |
| HTL/Push pull | |
| Load current | ≤ 30 mA |
| Power consumption | ≤ 0.5 W (without load) |
| TTL/HTL | |
| Load current | ≤ 30 mA |

| | | |
|-----------------------|-------------------|------------------------|
| | Power consumption | ≤ 0.5 W (without load) |
| Open Collector | | |
| | Load current | ≤ 30 mA |
| | Power consumption | ≤ 0.5 W (without load) |

Electrical data

| | |
|--|---|
| Connection type | Male connector, M23, 12-pin, radial |
| Supply voltage | 10 ... 32 V |
| Reference signal, number | 1 |
| Reference signal, position | 90°, electric, logically gated with A and B |
| Reverse polarity protection | ✓ |
| Short-circuit protection of the outputs | ✓ ¹⁾ |
| MTTFd: mean time to dangerous failure | 300 years (EN ISO 13849-1) ²⁾ |

¹⁾ Short-circuit opposite to another channel, US or GND permissible for maximum 30 s.

²⁾ This product is a standard product and does not constitute a safety component as defined in the Machinery Directive. Calculation based on nominal load of components, average ambient temperature 40 °C, frequency of use 8760 h/a. All electronic failures are considered hazardous. For more information, see document no. 8015532.

Mechanical data

| | |
|--|---|
| Mechanical design | Through hollow shaft |
| Shaft diameter | 14 mm |
| Weight | + 0.2 kg |
| Shaft material | Stainless steel |
| Flange material | Aluminum |
| Housing material | Aluminum die cast |
| Start up torque | 0.8 Ncm (+20 °C) |
| Operating torque | 0.6 Ncm (+20 °C) |
| Permissible shaft movement, axial static/dynamic | ± 0.5 mm / ± 0.2 mm |
| Permissible shaft movement, radial static/dynamic | ± 0.3 mm / ± 0.1 mm |
| Operating speed | ≤ 6,000 min ⁻¹ ¹⁾ |
| Moment of inertia of the rotor | 40 gcm ² |
| Bearing lifetime | 3.6 x 10 ¹⁰ revolutions |
| Angular acceleration | ≤ 500,000 rad/s ² |

¹⁾ Allow for self-heating of 3.3 K per 1,000 rpm when designing the operating temperature range.

Ambient data

| | |
|--------------------------------------|--|
| EMC | According to EN 61000-6-2 and EN 61000-6-4 |
| Enclosure rating | IP65, Housing side, male connector (according to IEC 60529) ¹⁾ IP65, shaft side (according to IEC 60529) |
| Permissible relative humidity | 90 % (condensation of the optical scanning not permitted) |
| Operating temperature range | 0 °C ... +85 °C |
| Storage temperature range | -40 °C ... +100 °C, without package |

¹⁾ With mating connector fitted.

| | |
|--------------------------------|--|
| Resistance to shocks | 50 g, 6 ms (according to EN 60068-2-27) |
| Resistance to vibration | 20 g, 10 Hz ... 2,000 Hz (according to EN 60068-2-6) |

¹⁾ With mating connector fitted.

Classifications

| | |
|-----------------------|----------|
| ECl@ss 5.0 | 27270501 |
| ECl@ss 5.1.4 | 27270501 |
| ECl@ss 6.0 | 27270590 |
| ECl@ss 6.2 | 27270590 |
| ECl@ss 7.0 | 27270501 |
| ECl@ss 8.0 | 27270501 |
| ECl@ss 8.1 | 27270501 |
| ECl@ss 9.0 | 27270501 |
| ECl@ss 10.0 | 27270501 |
| ECl@ss 11.0 | 27270501 |
| ETIM 5.0 | EC001486 |
| ETIM 6.0 | EC001486 |
| ETIM 7.0 | EC001486 |
| UNSPSC 16.0901 | 41112113 |

Dimensional drawing (Dimensions in mm (inch))

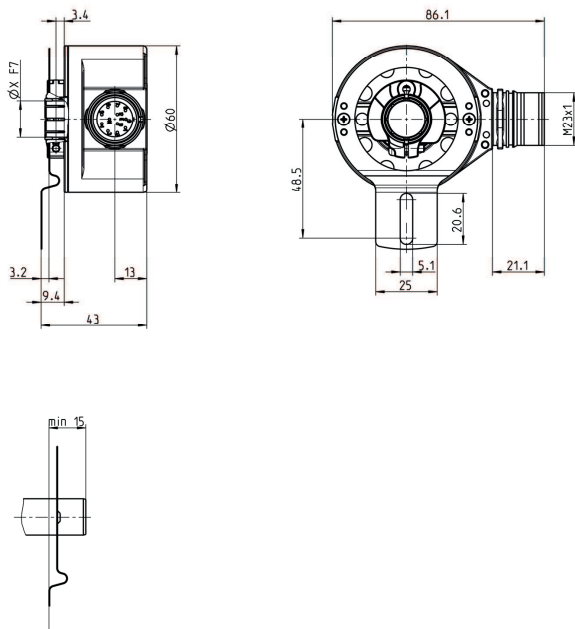

PIN assignment

| PIN | Signal TTL/HTL | Explanation |
|--------|-------------------|---|
| 1 | B ₋ | Signal line |
| 2 | N.C. | Not connected |
| 3 | Z | Signal line |
| 4 | Z ₋ | Signal line |
| 5 | A | Signal line |
| 6 | A ₋ | Signal line |
| 7 | N.C. | Not connected |
| 8 | B | Signal line |
| 9 | N.C. | Not connected |
| 10 | GND | Ground connection of the encoder |
| 11 | N.C. | Not connected |
| 12 | +U _s | Supply voltage potential free to housing |
| Shield | Shield | Screen on the encoder side connected to the housing. On the control side connected to earth. |

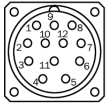

View of the connector M23 fitted to the encoder body

SICK AT A GLANCE

SICK is one of the leading manufacturers of intelligent sensors and sensor solutions for industrial applications. A unique range of products and services creates the perfect basis for controlling processes securely and efficiently, protecting individuals from accidents and preventing damage to the environment.

We have extensive experience in a wide range of industries and understand their processes and requirements. With intelligent sensors, we can deliver exactly what our customers need. In application centers in Europe, Asia and North America, system solutions are tested and optimized in accordance with customer specifications. All this makes us a reliable supplier and development partner.

Comprehensive services complete our offering: SICK LifeTime Services provide support throughout the machine life cycle and ensure safety and productivity.

For us, that is “Sensor Intelligence.”

WORLDWIDE PRESENCE:

Contacts and other locations –www.sick.com