



**Absolute encoders
ARS60 SSI/Parallel**

ARS60-F1A00360



Model Name > [ARS60-F1A00360](#)
Part No. > [1031558](#)



Illustration may differ

At a glance

- Absolute singleturn encoder
- Resolution: up to 15 bits (32,768 increments)
- Electrical interface: SSI with gray code type or gray capped
- Electrical interface: Parallel with gray, gray capped, binary, BCD code type
- Zero-set function
- Mechanical interfaces: face mount flange, servo flange, blind and through hollow shaft
- Enclosure rating: Up to IP66

Your benefits

- Optical and magnetic variants for the widest range of requirements
- Reduced maintenance costs thanks to magnetic, wearless scanning in single and multiturn design
- High level of productivity due to optical encoders with a high level of precision and fast calculation of positions
- Robust design for maximum system availability, even in extreme environmental conditions
- Absolutely compact - specially suited in cases where installation space is tight
- Flexible integration in all common networks



Performance

| | |
|--------------------------------------|--|
| Max. number of steps per revolution: | 360 |
| Max. number of revolutions: | 1 |
| Resolution power: | 360 x 1 |
| Error limits: | 0.035 ° (binary number of steps) 0.046 ° (non-binary number of steps) |
| Repeatability (Ta not constant): | 0.005 ° |
| Measuring step deviation: | 0.005 °, 0.016 ° |
| Measuring step: | 360 ° /number of lines |
| Initialization time: | 80 ms ¹⁾ |

¹⁾ Valid positional data can be read once this time has elapsed

Mechanical data

| | |
|-----------------------|---------------------------|
| Mechanical interface: | Solid shaft, Servo flange |
| Shaft diameter: | 6 mm |
| Mass: | 0.3 kg |

| | |
|-------------------------------------|--|
| Start up torque: | 0.25 Ncm |
| Operating torque: | 0.2 Ncm |
| Permissible Load capacity of shaft: | 10 N (axial), 20 N (radial) |
| Maximum operating speed: | 10,000 /min (without shaft seal), 6,000 /min (with shaft seal) ¹⁾ |
| Moment of inertia of the rotor: | 48 gcm ² |
| Bearing lifetime: | 3.6 x 10 ⁹ revolutions |
| Max. angular acceleration: | 500,000 rad/s ² |
| Operation of zero-set: | ≥ 100 ms ²⁾ |

¹⁾ If the shaft seal has been removed by the customer ²⁾ Only with shaft stationary (note initialisation time)

Electrical data

| | |
|--|--------------------------------------|
| Operating voltage range: | 10 V DC ... 32 V DC |
| Operating power consumption (no load): | 90 mA |
| MTTFd: mean time to dangerous failure: | 300 a (EN ISO 13849-1) ¹⁾ |

¹⁾ This product is a standard product and does not constitute a safety component as defined in the Machinery Directive.

Calculation based on nominal load of components, average ambient temperature 40°C, frequency of use 8760 h/a. All

electronic failures are considered hazardous. For more information, see document no. 8015532.

Interfaces

| | |
|-----------------------|-------------------------------|
| Electrical interface: | Connector M23, 21-pin, radial |
|-----------------------|-------------------------------|

Ambient data

| | |
|--------------------------------|--|
| EMC: | (according to EN 61000-6-2 and EN 61000-6-3) ¹⁾ |
| Enclosure rating: | IP 65 (according to IEC 60529), with mating connector fitted |
| Permissible relative humidity: | 90 % (condensation of the optical scanning not permitted) |
| Working temperature range: | -20 °C ... 85 °C |
| Storage temperature range: | -40 °C ... 100 °C |
| Resistance to shocks: | 50 g (according to EN 60068-2-27) |
| Resistance to vibration: | 20 g, 10 Hz ... 2,000 Hz (according to EN 60068-2-6) |

¹⁾

Dimensional drawing

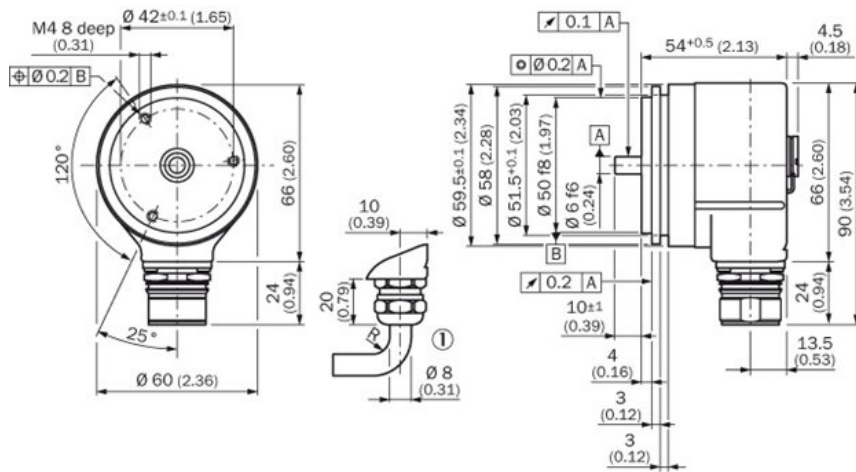

PIN assignment

• Allocation for encoder with 21-pin connector Single, Parallel Interface

| PIN | Wire color by cable outlet | Binary | Gray | BCD | Description |
|---------|----------------------------|--------------------------------|--------------------------------|----------------------------------|---------------------|
| 1 | Lilac | 2 ¹¹ | G ₁₁ | 2 ¹ ~ 10 ¹ | Data lines, outputs |
| 2 | White/brown | 2 ¹⁰ | G ₁₀ | 2 ¹ ~ 10 ⁰ | |
| 3 | White/green | 2 ⁹ | G ₉ | 2 ¹ ~ 10 ⁰ | |
| 4 | White/yellow | 2 ⁸ | G ₈ | 2 ¹ ~ 10 ⁰ | |
| 5 | White/gray | 2 ⁷ | G ₇ | 2 ¹ ~ 10 ⁰ | |
| 6 | White/pink | 2 ⁶ | G ₆ | 2 ¹ ~ 10 ⁰ | |
| 7 | White/blue | 2 ⁵ | G ₅ | 2 ¹ ~ 10 ⁰ | |
| 8 | White/red | 2 ⁴ | G ₄ | 2 ¹ ~ 10 ⁰ | |
| 9 | White/black | 2 ³ | G ₃ | 2 ¹ ~ 10 ⁰ | |
| 10 | Brown/green | 2 ¹⁰ | G ₁₀ | 2 ¹ ~ 10 ⁰ | |
| 11 | Brown/yellow | 2 ⁹ | G ₉ | 2 ¹ ~ 10 ⁰ | |
| 12 | Brown/gray | 2 ⁸ | G ₈ | 2 ¹ ~ 10 ⁰ | |
| 13 | Brown/pink | 2 ⁷ | G ₇ | 2 ¹ ~ 10 ⁰ | |
| 14 | Brown/blue | 2 ⁶ | G ₆ | 2 ¹ ~ 10 ⁰ | |
| 15 | Brown/red | 2 ⁵ | G ₅ | 2 ¹ ~ 10 ⁰ | |
| 16 | Green | Parity | Parity | Parity | |
| 17 | Pink | Store ₊ | Store ₊ | Store ₊ | |
| 18 | Yellow | Enable ₊ | Enable ₊ | Enable ₊ | |
| 19 | Brown | V ₁ /R ₁ | V ₁ /R ₁ | V ₁ /R ₁ | |
| 20 | Gray | SET | SET | SET | |
| 21 | Blue | GND | GND | GND | |
| Housing | Red | U ₁ | U ₁ | U ₁ | |
| | | Screen | Screen | Screen | |

¹ Set line only possible with a cable outlet.

U₁ Supply voltage to the encoder (before commissioning, note must be taken of the type label of the encoder).

GND Zero volt connection to the encoder; electrically isolated from the housing. The voltage referred to GND is U₁.

V₁/R₁ Forward/reverse: this input programs the counting direction of the encoder. If not connected, this input is high. If the encoder shaft, as viewed on the drive shaft, rotates in the clockwise direction, it counts in an increasing sequence. If it should count upwards when the shaft rotates in the anti-clockwise direction, this connection must be connected permanently to -low level (zero volts).

Enable₊ This input activates the data output driver when a -low level is applied. If not connected, this input is -low-. In the case of a -high- level, the outputs are in the inhibit mode.

Store₊ This input stores the encoder data in Gray code when a -low level is applied. This avoids a read error if the output data is requested in binary code. If this input is -low-, the data at the encoder output is stable, irrespective of whether the input shaft rotates. If not switched, this input is -high-.

Parity This output requires a -high- level when the parity checksum of the data bits is even.

SET This input serves to set the zero electronically. If the SET line is connected to U₁ for more than 100 ms, the mechanical position corresponds to the value 0.

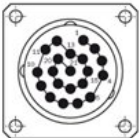

View of the connector M23 fitted to the encoder body Single, Parallel

Australia

Phone +61 3 9457 0600
1800 334 802 – tollfree
E-Mail sales@sick.com.au

Belgium/Luxembourg

Phone +32 (0)2 466 55 66
E-Mail info@sick.be

Brasil

Phone +55 11 3215-4900
E-Mail sac@sick.com.br

Canada

Phone +1 905 771 14 44
E-Mail information@sick.com

Ceská Republika

Phone +420 2 57 91 18 50
E-Mail sick@sick.cz

China

Phone +86 4000 121 000
E-Mail info.china@sick.net.cn
Phone +852-2153 6300
E-Mail ghk@sick.com.hk

Danmark

Phone +45 45 82 64 00
E-Mail sick@sick.dk

Deutschland

Phone +49 211 5301-301
E-Mail kundenservice@sick.de

España

Phone +34 93 480 31 00
E-Mail info@sick.es

France

Phone +33 1 64 62 35 00
E-Mail info@sick.fr

Great Britain

Phone +44 (0)1727 831121
E-Mail info@sick.co.uk

India

Phone +91-22-4033 8333
E-Mail info@sick-india.com

Israel

Phone +972-4-6801000
E-Mail info@sick-sensors.com

Italia

Phone +39 02 27 43 41
E-Mail info@sick.it

Japan

Phone +81 (0)3 3358 1341
E-Mail support@sick.jp

Magyarország

Phone +36 1 371 2680
E-Mail office@sick.hu

Nederlands

Phone +31 (0)30 229 25 44
E-Mail info@sick.nl

Norge

Phone +47 67 81 50 00
E-Mail austefjord@sick.no

Österreich

Phone +43 (0)22 36 62 28 8-0
E-Mail office@sick.at

Polska

Phone +48 22 837 40 50
E-Mail info@sick.pl

România

Phone +40 356 171 120
E-Mail office@sick.ro

Russia

Phone +7-495-775-05-30
E-Mail info@sick.ru

Schweiz

Phone +41 41 619 29 39
E-Mail contact@sick.ch

Singapore

Phone +65 6744 3732
E-Mail admin@sicksgp.com.sg

Slovenija

Phone +386 (0)1-47 69 990
E-Mail office@sick.si

South Africa

Phone +27 11 472 3733
E-Mail info@sickautomation.co.za

South Korea

Phone +82 2 786 6321/4
E-Mail info@sickkorea.net

Suomi

Phone +358-9-25 15 800
E-Mail sick@sick.fi

Sverige

Phone +46 10 110 10 00
E-Mail info@sick.se

Taiwan

Phone +886-2-2375-6288
E-Mail sales@sick.com.tw

Türkiye

Phone +90 (216) 528 50 00
E-Mail info@sick.com.tr

United Arab Emirates

Phone +971 (0) 4 8865 878
E-Mail info@sick.ae

USA/México

Phone +1(952) 941-6780
1 800-325-7425 – tollfree
E-Mail info@sickusa.com

More representatives and agencies
at www.sick.com