

L-GAGE LG Laser Gauging Sensors



Datasheet



- Self-contained Class 2 modulated visible laser gauging sensor needs no separate controller
- Narrow effective beam is excellent for precision gauging applications such as distance, height, or thickness measurement
- Resolution to better than 3 microns for LG5 Series models and better than 10 microns for LG10 Series models
- Banner's unique scalable analog output automatically distributes the output signal over the width of the programmed sensing window ¹
- Analog and discrete (switched) outputs with independent window limits
- Analog output slope is either positive or negative, depending upon which window limit is programmed first
- Fast, easy-to-use integrated push-button TEACH-mode programming; no potentiometer adjustments – Remote TEACH function for security and convenience
- Unique feature holds analog output value for 2 seconds upon loss of signal
- Modulated laser beam and narrow optical band-pass filter provide a high level of ambient light immunity, including immunity from high-energy factory lighting
- Alarm output for signal saturation and overload of discrete output
- Output response is programmable for three speeds
- Supply voltage: 12 to 30 V dc

Analog Current Output Models (4–20 mA)	Analog Voltage Output Models (0–10 V dc)	Sensing Distance	Focal Point ²	Cable ³	Discrete Output
LG5A65PI	LG5A65PU	45 to 60 mm (1.8 to 2.4 inches)	70 mm (2.8 inches) Beam size at 53 mm: 0.4 x 0.6 mm (0.016 x 0.024 inches)	2 m (6.5 ft) (8-wire)	PNP (Sourcing)
LG5A65PIQ	LG5A65PUQ			Pigtail QD (8-pin Euro)	
LG5A65NI	LG5A65NU			2 m (6.5 ft) (8-wire)	NPN (Sinking)
LG5A65NIQ	LG5A65NUQ			Pigtail QD (8-pin Euro)	
LG5B65PI	LG5B65PU		53 mm (2.1 inches) Beam size at 53 mm: 0.1 mm (0.004 inches)	2 m (6.5 ft) (8-wire)	PNP (Sourcing)
LG5B65PIQ	LG5B65PUQ			Pigtail QD (8-pin Euro)	
LG5B65NI	LG5B65NU			2 m (6.5 ft) (8-wire)	NPN (Sinking)
LG5B65NIQ	LG5B65NUQ			Pigtail QD (8-pin Euro)	
LG10A65PI	LG10A65PU	75 to 125 mm (2.9 to 4.9 inches)	180 mm (7.1 inches) Beam size at 125 mm: 0.06 x 0.8 mm (0.024 x 0.031 inches)	2 m (6.5 ft) (8-wire)	PNP (Sourcing)
LG10A65PIQ	LG10A65PUQ			Pigtail QD (8-pin Euro)	
LG10A65NI	LG10A65NU			2 m (6.5 ft) (8-wire)	NPN (Sinking)
LG10A65NIQ	LG10A65NUQ			Pigtail QD (8-pin Euro)	



WARNING: Not To Be Used for Personnel Protection

Never use this device as a sensing device for personnel protection. Doing so could lead to serious injury or death. This device does not include the self-checking redundant circuitry necessary to allow its use in personnel safety applications. A sensor failure or malfunction can cause either an energized or de-energized sensor output condition.

¹ Patent pending

² The focal point is the distance, measured from the sensor lens, at which the laser image is smallest.

³ To order the 9 m (30 ft) cable model, add suffix "W/30" to the cabled model number (LG5A65PI W/30).

Overview

Banner's Class 2 visible laser displacement sensor brings a sophisticated yet cost-effective solution to precision measurement applications. L-GAGE Series sensors feature all-in-one design and require no separate controller.

The L-Gage Laser Gauging System operates in two modes: TEACH (or programming) and RUN. Near and far sensing window limits are set quickly using simple push-button or remote signal TEACH-mode programming. One sensor can simultaneously provide both analog and discrete (switched) outputs. Sensing window limits for each output may be independently programmed. The analog signal features Banner's unique scalable output (patent pending), which automatically distributes the output signal over the width of the programmed sensing window.

The L-GAGE Laser Gauging Sensor boasts many additional features, including selectable response speed, self-diagnostics with alarm output, comprehensive status indicator system, and unique output "hold" function in case of momentary signal loss in profiling applications.

Optical Triangulation

The design of the L-GAGE Laser Gauging Sensor is based on optical triangulation. An emitter transmits visible laser light through a lens, toward a target. The laser light beam from the emitter bounces off the target, scattering some of its light through another lens to the sensor's PSD (position-sensitive device) receiver element. The target's distance from the receiver determines the angle the light travels to the receiver element; this angle in turn determines where the received light will fall along the PSD receiver element.

The position of the light on the PSD receiver element is processed through analog and digital electronics and analyzed by the microprocessor, which calculates the appropriate output value. The analog output provides a variable signal that is proportional to the target's position within the user-programmed analog window limits (see page 3). The discrete (switched) output energizes whenever the target is located between the user-programmed discrete window limits. Analog and discrete window limits may be the same, or programmed independently.

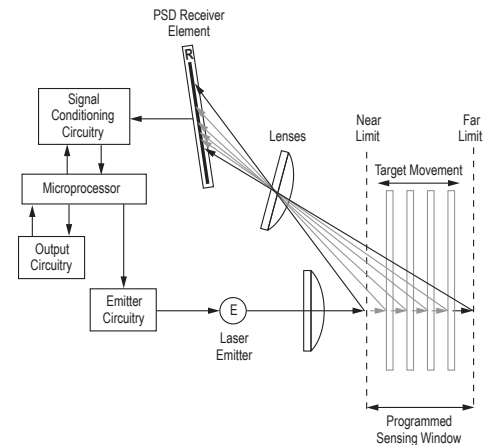

Sensor Programming

Program the sensor using either the sensor's keypad or via remote programming. Remote programming is also used to disable the keypad for security, preventing unauthorized or accidental programming adjustment on the production floor.

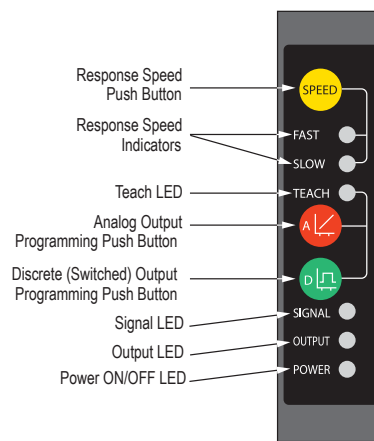

Remote Programming

For remote programming, connect the sensor's yellow wire to +5 to 30V dc, with a remote programming switch connected between them. The impedance of the remote teach input is 18 k Ω minimum (65 k Ω minimum at 5V).

To program the sensor, follow the sequence of input pulses, button pushes, and “clicks” for programming on the sensor buttons. The duration of each pulse (corresponding to a push button “click”), and the period between multiple pulses, are defined as: 0.04 seconds < T < 0.8 seconds.

Analog Output Slope

The L-GAGE Laser Gauge may be programmed for either a positive or a negative output slope, based on which condition is taught first. If the near limit is taught first, the slope will be positive; if the far limit is taught first, the slope will be negative. Banner’s unique scalable analog output (patent pending) automatically distributes the output signal over the width of the programmed sensing window. Factory analog output is 0 to 10V dc (LG..U models) or 4 to 20 mA (LG..I models).

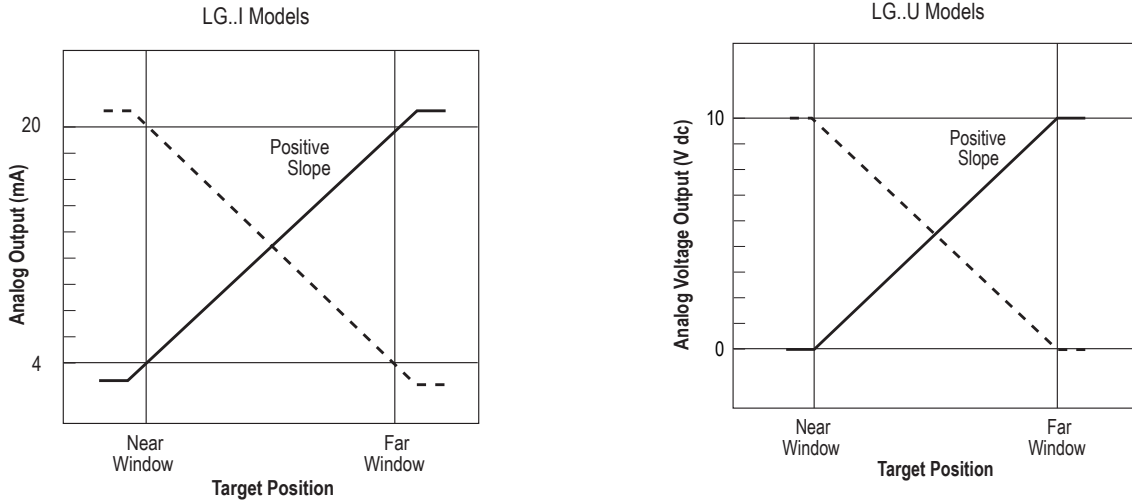

Analog output as a function of target position

The L-GAGE also features a 2-second hold upon loss of the analog signal, which is useful for profiling and similar applications. In the event of analog signal loss for longer than 2 seconds, the analog output goes to 0V dc (LG..U models) or 4 mA (LG..I models).

Teaching Analog Limits Using the Auto-Zero Feature (Analog Output)

For some analog applications, a sensing distance set point centered within a sensing window may be required. The TEACH procedure is simple: teaching the same limit twice causes the sensor to program a window centered on the position taught. This window is 10 mm wide (taught position ± 5 mm).

Teaching Fixed-Field Sensing Mode (Discrete Output)

Teaching the same limit twice creates a sensing window with the far limit at the teach distance and the near limit at the minimum operating range of the sensor (approx. 42 mm for LG5 Series models, and approx. 60 mm for LG10 Series models).

Beam Dimensions (Typical)				
	Focal Point	Distance	Beam Width (X)	Beam Height (Y)
	LG5 Series			
	53 mm (2.1 inches)	45 mm	0.3 mm	0.5 mm
		53 mm	0.1 mm	0.1 mm
		60 mm	0.3 mm	0.5 mm
	70 mm (2.8 inches)	45 mm	0.6 mm	0.9 mm
		53 mm	0.4 mm	0.6 mm
		60 mm	0.3 mm	0.4 mm
	LG10 Series			
	180 mm (7.1 inches)	75 mm	1.1 mm	1.5 mm
		100 mm	0.8 mm	1.1 mm
125 mm		0.6 mm	0.8 mm	

The focal point is the distance, measured from the sensor lens, at which the laser image is smallest.

Teaching Limits for Either Analog or Discrete Output

Either output may be programmed first.

	Push Button (0.04 sec. < "click" < 0.8 sec.)		Remote Wire (0.04 sec. < T < 0.8 sec.)	
	Procedure	Result	Procedure	Result
Program ming Mode	Push and hold push button for Analog or Discrete output for more than 2 seconds *	TEACH LED turns ON Red — Analog output Green — Discrete output Sensor is waiting for first limit	No action required	
Teach First Limit	Position the target for the first limit "Click" the same push button	TEACH LED flashes at 2 Hz Sensor learns first limit and waits for second limit	Position the target for the first limit Analog Output: double-pulse the remote line Discrete Output: single-pulse the remote line	TEACH LED turns ON: Red — Analog output Green — Discrete output TEACH LED flashes at 2 Hz Sensor learns first limit and waits for second limit
Teach Second Limit	Position the target for the second limit "Click" the same push button	TEACH LED goes OFF Sensor learns second limit and returns automatically to RUN mode	Position the target for the second limit Single-pulse the remote line	TEACH LED goes OFF Sensor learns second limit and returns automatically to RUN mode
Program Second Output	Repeat for other output, if a second output is desired.			

* Sensor will return to Run mode if first TEACH condition is not registered within 120 seconds.

Teaching Limits for Analog and Discrete Outputs Simultaneously

Both analog and discrete outputs will have identical limits.

	Push Button (0.04 sec. < "click" < 0.8 sec.)		Remote Wire (0.04 sec. < T < 0.8 sec.)	
	Procedure	Result	Procedure	Result
Programming Mode	Push and hold either push button for more than 2 seconds* Briefly "click" the other button	TEACH LED turns ON: Yellow Sensor is waiting for first limit	No action required	
Teach First Limit	Position the target for the first limit "Click" either push button	TEACH LED flashes at 2 Hz, alternating Red and Green Sensor learns first limit and waits for second limit	Position the target for the first limit Triple-pulse the remote line	TEACH LED turns ON: Yellow Sensor learns first limit and waits for second limit TEACH LED flashes at 2 Hz, alternating Red and Green
Teach Second Limit	Position the target for the second limit "Click" either push button	TEACH LED goes OFF Sensor learns second limit and returns automatically to Run mode	Position the target for the second limit Single-pulse the remote line	TEACH LED goes OFF Sensor learns second limit and returns automatically to Run mode

* Sensor will return to Run mode if first TEACH condition is not registered within 120 seconds

Sensor Configuration

Response Speed. Use the Speed push button to toggle between the three response speed settings. The combination of indicator lights (Fast and Slow) will tell you which of the three is selected:

Slow	Fast	Analog Output Frequency Response (-3 dB)	Discrete Output Response Speed
ON	OFF	4.5 Hz	100 milliseconds
ON	ON	45 Hz	10 milliseconds
OFF	ON	450 Hz	2 milliseconds

Push Button Lockout. Enables or disables the keypad to prevent accidental or unauthorized adjustment of the programming settings.

	Procedure		Result
	Push Button	Remote Wire (0.04 sec. < T < 0.8 sec.)	
Enable/Disable Push Buttons	Not available via push button	Four-pulse the remote line	Push buttons are either enabled or disabled, depending on previous condition

Indicators

Signal LED. The Signal LED indicates the strength and condition of the sensor's incoming signal.

Signal LED Status	Indicates
OFF	No signal is received, or the target is beyond the range limitations of the sensor (with some tolerance beyond the recommended minimum and maximum sensing distance)
Flashing at 2 Hz	Received signal is adequate for processing
Flashing at 10 Hz	Received signal is in saturation (i.e., signal is too strong); alarm output energizes
ON Solid	Received signal is within the nominal conditions for the sensor

Output LED. The Output LED lights when the discrete output is conducting.

Power ON/OFF LED. The Power ON/OFF LED indicates the operating status of the sensor.

Power ON/OFF LED Status	Indicates
OFF	Power is OFF
Flashing at 2 Hz	Discrete or alarm output is overloaded
Flashing at 10 Hz	Power ON, Laser is disabled
ON Solid	Sensor is operating normally (power is ON, Laser enabled)

Power Up/Laser Enable. When powering up the sensor, the following should occur:

- All LEDs turn ON for 1 second
- Allow 1.25 second delay for Laser Enable at power up. (If sensor is already powered up, allow 0.25 second for Laser Enable.)

Installation Notes

Some targets (those with a stepped plane facing the sensor, a boundary line, or rounded targets) pose specific problems for sensing distances. The following two images illustration sensor orientations for typical targets.

Recommended

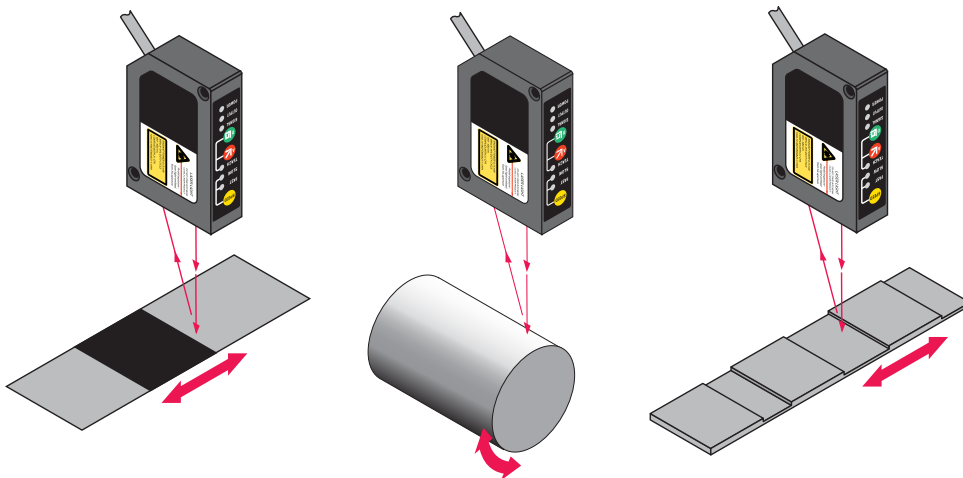

Not Recommended

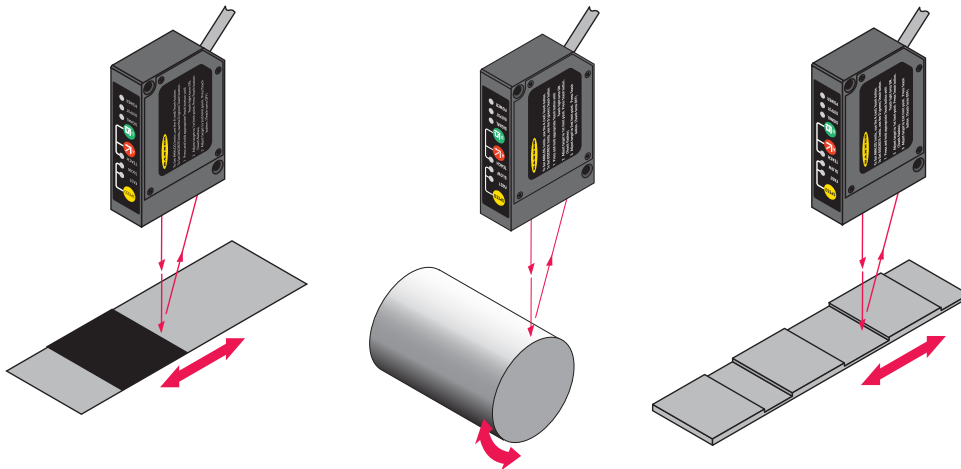

WARNING: Class 2 Safety Notes

Low-power lasers are by definition incapable of causing eye injury within the duration of the blink, or aversion response of 0.25 seconds. They must also emit only visible wavelengths (400-700 nm). Therefore, an ocular hazard can only exist if an individual overcomes their natural aversion to bright light and stares directly into the laser beam. The device requirements for these lasers are to have a [hazard] label and to have an indicator light to indicate laser emission.

The two operational safety rules are:

- Do not permit a person to stare at the laser from within the beam
- Do not point the laser at a person's eye at close range



LASER LIGHT

DO NOT STARE INTO BEAM
CLASS 2 LASER PRODUCT

**Avoid exposure -
laser light emitted
from this aperture**

RADIANT POWER 0.2 mW
9.8KHz 11-20% DUTY CYCLE
640 - 660 nm
Complies to 21CFR, Parts 1040.10 and 1040.11 except for deviations pursuant to Laser Notice 50, dated 7-26-01.



WARNING:

Beam Paths

The beam emitted by a class 2 laser product should be terminated at the end of its useful path. Open laser beam paths should be located above or below eye level where practical.



CAUTION: Do Not Disassemble for Repair

This device contains no user-serviceable components. Do not attempt to disassemble for repair. Use of controls or adjustments or performance of procedures other than those specified herein may result in hazardous radiation exposure. A defective unit must be returned to the manufacturer.

Specifications

Supply Voltage

12 to 30 V dc (10% maximum ripple); 50 mA max at 24 V dc (exclusive of load)

Supply Protection Circuitry

Protected against reverse polarity and transient over voltages

Sensing Range

LG5: 45 to 60 mm (1.77 to 2.36 inches)
 LG10: 75 to 125 mm (2.95 to 4.92 inches)

Delay at Power-up

1.25 seconds

Sensing Beam

650 nm visible red IEC and CDRH Class 2 laser; 0.20 mW radiant output power

Adjustments

Response speed: Push button toggles between Slow, Medium, and Fast (see Output Response Time)

Window limits (analog or discrete): TEACH-mode programming of near and far window limits (see programming procedure). Limits may also be taught remotely.

Analog output slope: The first limit taught is assigned to the minimum analog output.

Construction

Housing: Zinc alloy die-cast, plated and painted finish
 Cover plate: aluminum with painted finish
 Lens: acrylic

Connections

2 m (6.5') or 9 m (30') 7-conductor shielded PVC-jacketed attached cable, or 150 mm (6") 8-pin Euro-style pigtail quick-disconnect. Mating QD cables are purchased separately.

Vibration and Mechanical Shock

Vibration: 60 Hz, 30 minutes, 3 axes
 Shock: 30G for 11 milliseconds, half sine wave, 3 axes

Indicators

Green Power ON LED: Indicates when power is ON, overloaded output and laser status.

Yellow Output LED: Indicates when discrete load output is conducting.

Red Signal LED: Indicates target is within sensing range and the condition of the received light signal.

Tri-color Red/Green/Yellow TEACH LED: Indicates sensor is ready for programming each limit (indicates red for analog output, green for discrete, and yellow for simultaneous analog and discrete.)

Yellow Fast/Slow LEDs: Combination of 2 lights ON or OFF indicates 1 of 3 response speeds.

Output Configurations

Discrete (switched) and alarm outputs: SPST solid-state switch; choose NPN (current sinking) or PNP (current sourcing) models

Analog current output (LG...I Models): 4 to 20 mA or 20 to 4 mA (current sourcing)

Analog voltage output (LG...U Models): 0 to 10 V dc or 10 to 0 V dc (voltage sourcing)

Output Ratings

Discrete (switched) and Alarm outputs: 100 mA maximum

OFF-state leakage current: less than 5 microamps

Output saturation voltage - PNP outputs: less than 1.2 volts at 10 mA and less than 1.6 volts at 100 mA

Output saturation voltage - NPN outputs: less than 200 millivolts at 10 mA and less than 600 millivolts at 100 mA

Analog output (LG...I Models): 1 k Ω max at 24 V dc, max load resistance = $[(V_{cc} - 4.5)/0.02]\Omega$

Analog output (LG...U Models): 2.5 k Ω minimum load impedance

Output Protection

Discrete and alarm outputs are protected against continuous overload and short circuit

Analog Output (-3 dB) Response Time

Fast: 450 Hz (1 millisecond average with 1 millisecond update rate)

Medium: 45 Hz (10 millisecond average with 2 millisecond update rate)

Slow: 4.5 Hz (100 millisecond average with 5 millisecond update rate)

Discrete Output Response Time

Fast: 2.0 milliseconds ON and OFF

Medium: 10 milliseconds ON and OFF

Slow: 100 milliseconds ON and OFF

Environmental rating

IP67, NEMA 6

Operating Conditions

Temperature: -10 °C to 50 °C (14 °F to 122 °F)

Maximum relative humidity: 90% at +50 °C, non-condensing

Analog Resolution and Repeatability of Discrete Trip Point* (LG5)

- Fast: < 40 microns @ 50 mm
- Medium: < 12 microns @ 50 mm
- Slow: < 3 microns @ 50 mm

Analog Linearity* (LG5)

- ±60 microns (±0.002") over 45 to 60 mm sensing window
- ±10 microns (±0.0003") over 49 to 51 mm sensing window

Minimum Window Size (Analog or Discrete)

- LG5: 1.5 mm (0.06")
- LG10: 5 mm (0.2")

Color Sensitivity (typical)

- LG5: < 75 microns (0.003") for white to dark gray ceramic target
- LG10: < 100 microns (0.004") for white to dark gray ceramic target

Remote TEACH and Laser Control Input Impedance

18 kΩ minimum (65 kΩ at 5V dc)

Remote TEACH

- To teach: Connect yellow wire to +5 to 30 V dc
- To disable: Connect yellow wire to 0 to +2 V dc (or open connection)

Analog Resolution and Repeatability of Discrete Trip Point* (LG10)

- Fast: < 150 microns @ 100 mm
- Medium: < 50 microns @ 100 mm
- Slow: < 10 microns @ 100 mm

Analog Linearity* (LG10)

- ±200 microns (±0.008") over 75 to 125 mm sensing window
- ±20 microns (±0.0008") over 95 to 100 mm sensing window

Hysteresis (Discrete Output)

- LG5: < 0.2 mm (0.008")
- LG10: < 1.0 mm (0.04")

Temperature Drift

- LG5: ±7 microns/°C
- LG10: ±25 microns/°C

Laser Control

- To enable laser: Connect green wire to +5 to 30 V dc
- To disable laser: Connect green wire to 0 to +2 V dc (or open connection)
- 250 millisecond delay upon enable/disable

*Resolution and linearity specified @ 24 V dc, 22 °C, using a white ceramic test surface (see Application Notes)

Certifications



Application Notes

For comparison, a white ceramic test surface has approximately 91% of the reflectivity of a white Kodak test card with a matte finish. A dark gray ceramic test surface has approximately 11% of the reflectivity of a white Kodak test card with a matte finish. (Allow 15-minute warm-up for maximum linearity.)

Resolution

The following charts illustrate the L-GAGE resolution with respect to speed (typical, using a white ceramic target).

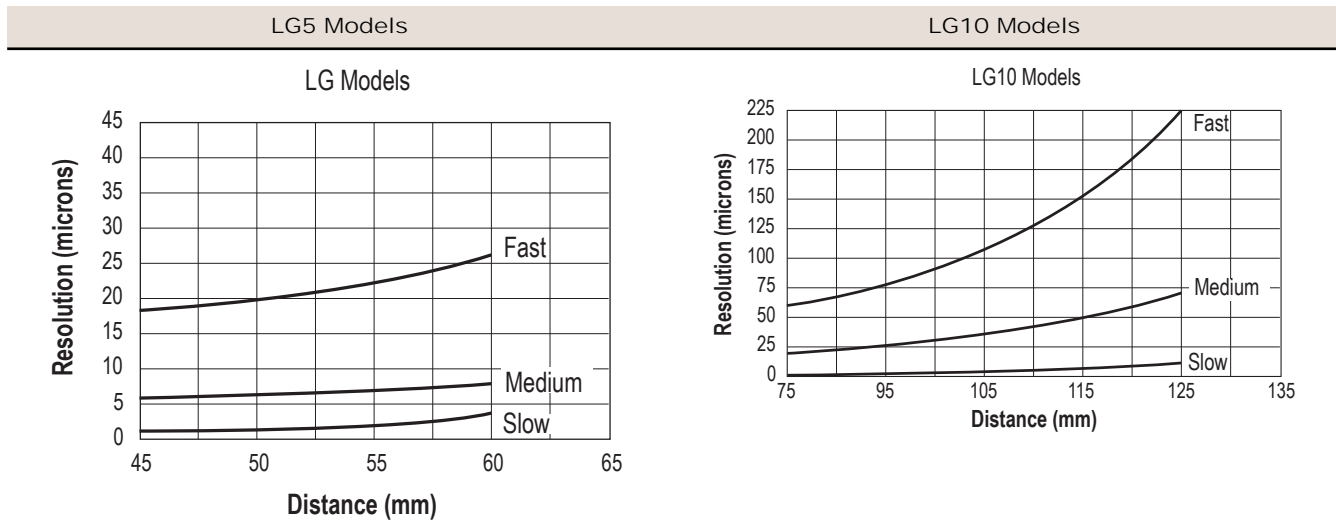

Dimensions

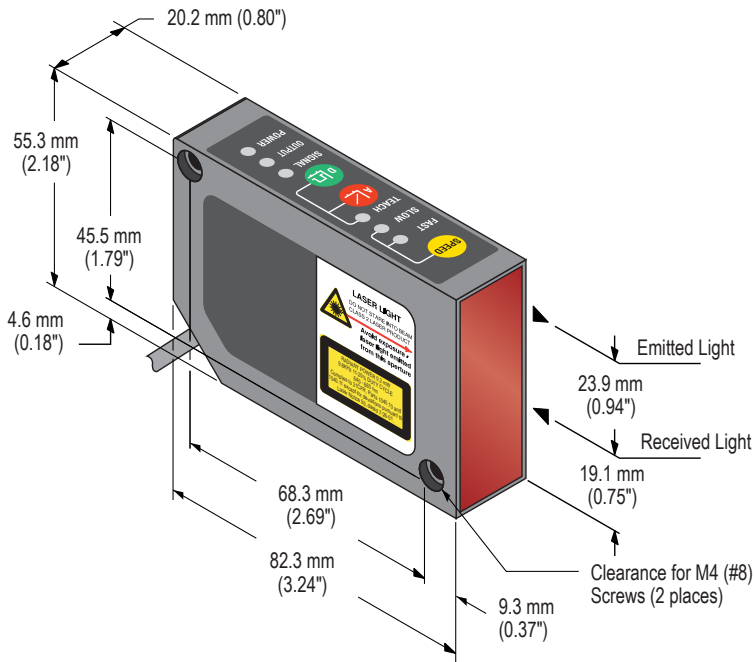

Mounting hardware (M4) is included.

Wiring Diagrams

Wiring connections are functionally identical for either integral or QD cable.

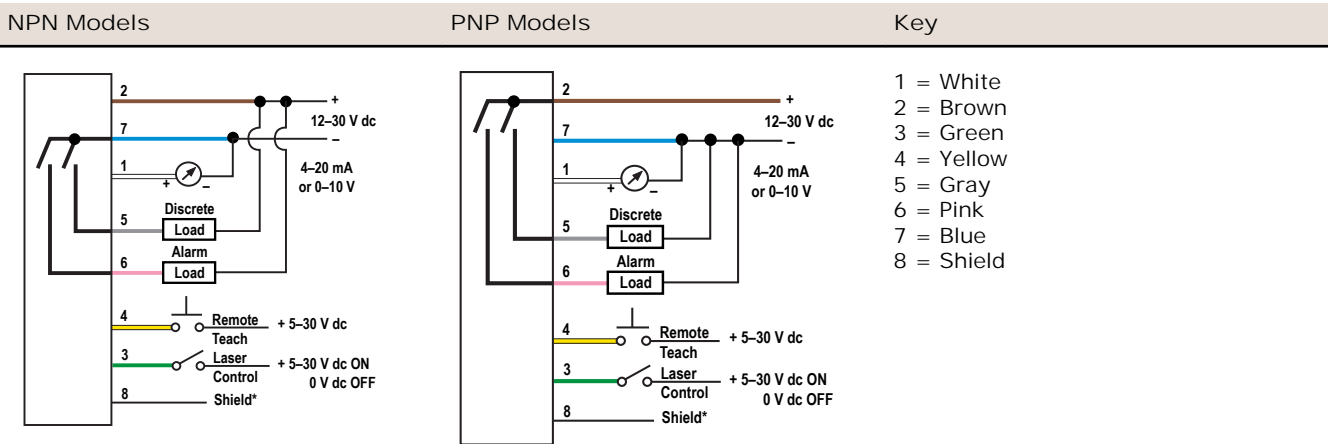

Conversion from Current to Voltage Output (LGxI Models Only)	Typical Voltage Response	
	Value of R	Output Voltage
	250 Ω	1 to 5V
	500 Ω	2 to 10V

**For best results, install a small amount of capacitance (e.g., 0.1 μF) in parallel with the load resistor

† 4 to 20 mA (LG..I models) or 0 to 10V dc (LG..U models)

*The bare shield wire is connected internally to the sensor housing and should be connected as follows:

1. If the sensor housing is mounted so that it is in continuity with both the machine frame and earth ground, connect the bare wire (also) to earth ground.
2. If the sensor housing is mounted so that it is insulated from the machine frame, connect the bare wire to -V dc (together with the blue wire).
3. If the sensor is mounted so that it is in continuity with the machine frame, but not with earth ground, do not connect the bare wire (i.e. cut off the bare wire).

Accessories

Cordsets

8-Pin Threaded M12/Euro-Style Cordsets with Shield				
Model	Length	Style	Dimensions	Pinout
MQDC-806	1.83 m (6 ft)	Straight		
MQDC-815	4.57 m (15 ft)			
MQDC-830	9.14 m (30 ft)			
				1 = White 5 = Gray 2 = Brown 6 = Pink 3 = Green 7 = Blue 4 = Yellow 8 = Shield

Brackets

SMBLG <ul style="list-style-type: none"> • L-GAGE sensor mounting bracket • 304 Stainless Steel 	SMBLGA <ul style="list-style-type: none"> • L-GAGE adjustable bracket assembly • 304 Stainless Steel
---	--

Banner Engineering Corp Limited Warranty

Banner Engineering Corp. warrants its products to be free from defects in material and workmanship for one year following the date of shipment. Banner Engineering Corp. will repair or replace, free of charge, any product of its manufacture which, at the time it is returned to the factory, is found to have been defective during the warranty period. This warranty does not cover damage or liability for misuse, abuse, or the improper application or installation of the Banner product.

THIS LIMITED WARRANTY IS EXCLUSIVE AND IN LIEU OF ALL OTHER WARRANTIES WHETHER EXPRESS OR IMPLIED (INCLUDING, WITHOUT LIMITATION, ANY WARRANTY OF MERCHANTABILITY OR FITNESS FOR A PARTICULAR PURPOSE), AND WHETHER ARISING UNDER COURSE OF PERFORMANCE, COURSE OF DEALING OR TRADE USAGE.

This Warranty is exclusive and limited to repair or, at the discretion of Banner Engineering Corp., replacement. IN NO EVENT SHALL BANNER ENGINEERING CORP. BE LIABLE TO BUYER OR ANY OTHER PERSON OR ENTITY FOR ANY EXTRA COSTS, EXPENSES, LOSSES, LOSS OF PROFITS, OR ANY INCIDENTAL, CONSEQUENTIAL OR SPECIAL DAMAGES RESULTING FROM ANY PRODUCT DEFECT OR FROM THE USE OR INABILITY TO USE THE PRODUCT, WHETHER ARISING IN CONTRACT OR WARRANTY, STATUTE, TORT, STRICT LIABILITY, NEGLIGENCE, OR OTHERWISE.

Banner Engineering Corp. reserves the right to change, modify or improve the design of the product without assuming any obligations or liabilities relating to any product previously manufactured by Banner Engineering Corp.