

**Photoelectric sensor
base unit for optical fibers
D12SP6FPY1Q**

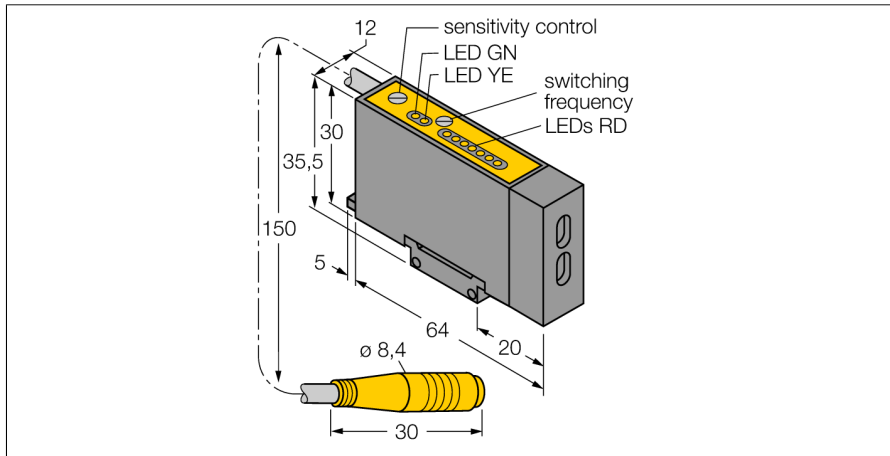

- Base unit for plastic fibers
- 7-segment LED chain for indication of excess gain
- connector 8 mm
- Operating voltage 10...30 VDC
- PNP transistor switching output
- Max. switching frequency 10 kHz
- Switch-off delay 20 ms
- Sensitivity adjustable via potentiometer

Wiring diagram

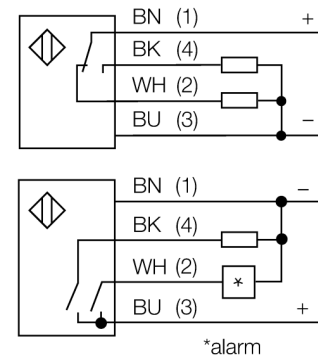

Functional principle

Glass or fibre optic sensors are the optimum choice for high temperature or space restricted applications. Fibre optics transfer the light from the sensor to a remote object. Individual fibre optics are used for opposed mode sensing, whereas bifurcated fibre optics are suited for retro-reflective or diffuse mode operation.

Excess gain curve

Excess gain in relation to the distance

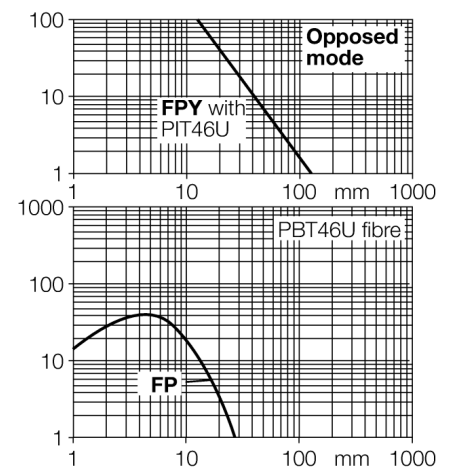

Type code	D12SP6FPY1Q
Ident no.	3035504
Operating mode	fibre optic sensor
Light type	red
Wavelength	680 nm
Ambient temperature	-20...+70 °C
Operating voltage	10...30VDC
No-load current I ₀	≤ 25 mA
Output function	NO/NC , PNP
Switching frequency	10 kHz
Readiness delay	≤ 20 ms
Overcurrent release	> 200 mA
Design	rectangular, D12
Dimensions	64 x 12 x 30 mm
Housing material	plastic, ABS
Connection	cable with connector, Ø 8 mm
Protection class	IP66
Power-on indication	LED green
Switching state	LED yellow
Error indication	LED red flashing
Excess gain indication	LED chain red