

Inductive sensor NI8-G12K-AD4X

TURCK

Industrial
Automation

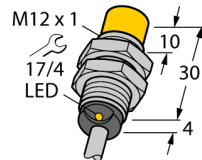

- Threaded barrel, M12x1
- Chrome-plated brass
- 2-wire DC, 10...65 VDC
- NO contact
- Cable connection

Wiring diagram

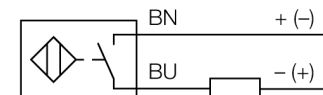

Functional principle

Inductive sensors detect metal objects contactless and wear-free. For this, they use a high-frequency electromagnetic AC field that interacts with the target. Inductive sensors generate this field via an RLC circuit with a ferrite coil.

We offer special versions for temperatures of -60 °C up to +250 °C.

Type code	NI8-G12K-AD4X
Ident no.	4411230
Rated operating distance Sn	8 mm
Mounting condition	non-flush
Assured sensing range	≤ (0,81 x Sn) mm
Correction factors	St37 = 1; Al = 0.3; stainless steel = 0.7; Ms = 0.4
Repeatability	≤ 2 % of full scale
Temperature drift	10 %
Hysteresis	1...15 %
Ambient temperature	-25...+70 °C
Operating voltage	10...65VDC
Residual ripple	≤ 10 % U _{ss}
DC rated operational current	≤ 100 mA
Residual current	≤ 0.6 mA
Rated insulation voltage	≤ 0.5 kV
Short-circuit protection	yes/ cyclic
Voltage drop at I _s	≤ 5 V
Smallest operating current I _m	≤ 3 mA
Switching frequency	0.5 kHz
Design	threaded barrel, M12 x 1
Dimensions	34 mm
Housing material	metal, CuZn, chrome-plated
Material active area	Plastic, PA
Max. tightening torque housing nut	10 Nm
Connection	cable
Cable quality	5.2 mm, LifYY, PVC, 2 m
Cable cross section	2 x 0.34 mm ²
Vibration resistance	55 Hz (1 mm)
Shock resistance	30 g (11 ms)
Protection class	IP67
MTTF	2283 years acc. to SN 29500 (Ed. 99) 40 °C
Switching state	LED yellow

**Inductive sensor
NI8-G12K-AD4X**

Distance D	3 x B
Distance W	3 x Sn
Distance T	3 x B
Distance S	1.5 x B
Distance G	6 x Sn
Distance N	2 x Sn

Diameter of the active area B \varnothing 12 mm

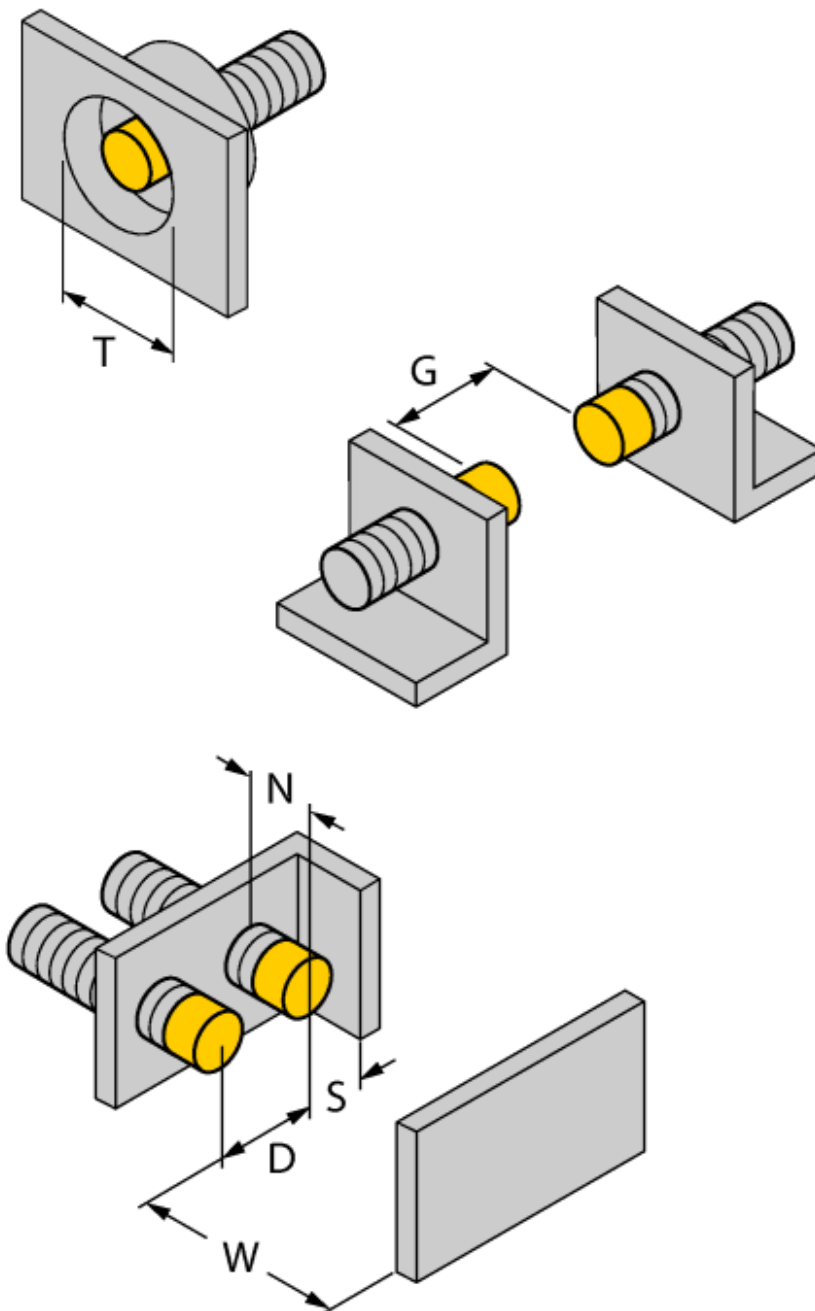

Accessories

Type code	Ident no.	Description	Dimension drawing
BST-12B	6947212	Fixing clamp for threaded barrel devices, with dead-stop; material: PA6	
QM-12	6945101	Quick-mount bracket with dead-stop; material: Chrome-plated brass Male thread M16 x 1. Note: The switching distance of proximity switches can be reduced by the use of quick-mount brackets.	
MW-12	6945003	Mounting bracket for threaded barrel devices; material: Stainless steel A2 1.4301 (AISI 304)	
BSS-12	6901321	Mounting bracket for smooth and threaded barrel devices; material: Polypropylene	