



Motor feedback systems rotary HIPERFACE® SFS/SFM60

SFS60-H1BT1K02



Model Name > SFS60-H1BT1K02
Part No. > -*



Illustration may differ

* When ordering for the first time, please use the information in "Model Name" instead of "Part No."

At a glance

- HIPERFACE® motor feedback system in singleturn and multiturn design, compatible with the world's leading drive systems
- 1,024 sine/ cosine periods per revolution
- Absolute position with a resolution of 32,768 increments per revolution and 4,096 revolutions with the multiturn system
- HIPERFACE® interface: Programming of the position value and electronic type label
- Mechanical flexibility through different blind hollow shaft and through hollow shaft diameters (8 to 15 mm diameter), available with various torque supports
- Unique ball bearing design, allowing for a ball bearing distance of 30 mm.
- Universal cable outlet and common connector versions
- Protection class IP 65

Your benefits

- Convenient traceability and simple maintenance thanks to storage of motor-specific data in the electronic type label
- Large ball bearing distances reduce uneven wear and minimize vibration on the encoder housing, which increases the encoder's service life
- The nickel code disk offers a high degree of vibration resistance and an extended temperature range
- Shorter development times through standardized mechanical interface
- Platform for the future, since all electrical interfaces (TTL/HTL, 1Vpp, SSI, PROFIBUS, HIPERFACE DSL®) are or will be available in this mechanical component.



Performance

Number of sine/cosine periods per revolution:	1,024
Number of the absolute ascertainable revolutions:	1 (Singleturn)
Total number of steps:	32,768
Measuring step:	0.3 angular seconds at interpolation of the sine/cosine signals with e.g. 12 Bit
Error limits for the digital absolute value:	± 90 angular seconds (via RS485)
Integral non-linearity typ.:	± 45 angular seconds (Error limits for evaluating sine/cosine period) without mechanical tension of the stator coupling
Differential non-linearity:	± 7 angular seconds (Non-linearity within a sine/cosine period)
Operating speed:	6,000 /min, up to which the absolute position can be reliably produced

Available memory area: 1,792 Byte (EEPROM 2048)

Mechanical data

Shaft diameter:	3/8 "
Shaft plug-in length:	15 mm
Flange type/stator coupling:	Version 1
Dimensions:	See dimensional drawing
Mass:	0.2 kg
Moment of inertia of the rotor:	40 gcm ²
Maximum operating speed:	9,000 /min ¹⁾
Maximum angular acceleration:	50,000 rad/s ²
Operating torque:	0.6 Ncm (20 °C)
Start up torque:	0.8 Ncm (20 °C)
Permissible shaft movement, radial, static:	± 0.3 mm
Permissible shaft movement, radial, dynamic:	± 0.1 mm
Permissible shaft movement, axial, static:	± 0.5 mm
Permissible shaft movement, axial, dynamic:	± 0.2 mm
Life of ball bearings:	3.6 x 10 ⁹ revolutions
Connection type:	Connector M12, 8-pin, radial
Shaft version:	Through hollow shaft

¹⁾ Self-warming 3.3 K/1,000 1/min, when applying note working temperature range

Electrical data

Electrical interface:	HIPERFACE
Operating voltage range/supply Voltage:	7 V DC ... 12 V DC
Recommended supply voltage:	8 V DC
Output frequency for sine/cosine signals:	0 kHz ... 200 kHz
Operating power consumption (no load):	< 80 mA ¹⁾

¹⁾ Without load

Interfaces

Type of code for the absolute value:	Binary
Code sequence:	Increasing, for clockwise shaft rotation, looking in direction "A" (see dimensional drawing)
Interface signals:	Parameter channel RS 485: digital, Process data channel SIN, REFSIN, COS, REFCOS: analog, differential

Ambient data

Working temperature range:	-30 °C ... 115 °C
Storage temperature range:	-40 °C ... 115 °C, without package
Relative humidity/Condensation:	90 %, Condensation not permitted
Resistance to shocks:	100 g, 6 ms (according to EN 60068-2-27)
Resistance to vibration:	20 g, 10 Hz ... 2,000 Hz (according to EN 60068-2-6)
EMC:	According to EN 61000-6-2 and EN 61000-6-3 ¹⁾
Enclosure rating:	IP 65, according to IEC 60529, with mating connector inserted

¹⁾ The EMC according to the standards quoted is achieved when the motor feedback system is mounted in an electrically conductive housing, which is connected to the central earthing point of the motor controller via a cable screen. This is also where the GND (0 V) connection of the power supply voltage is linked to earth. Users must perform their own tests when other screen designs are used.

Dimensional drawing

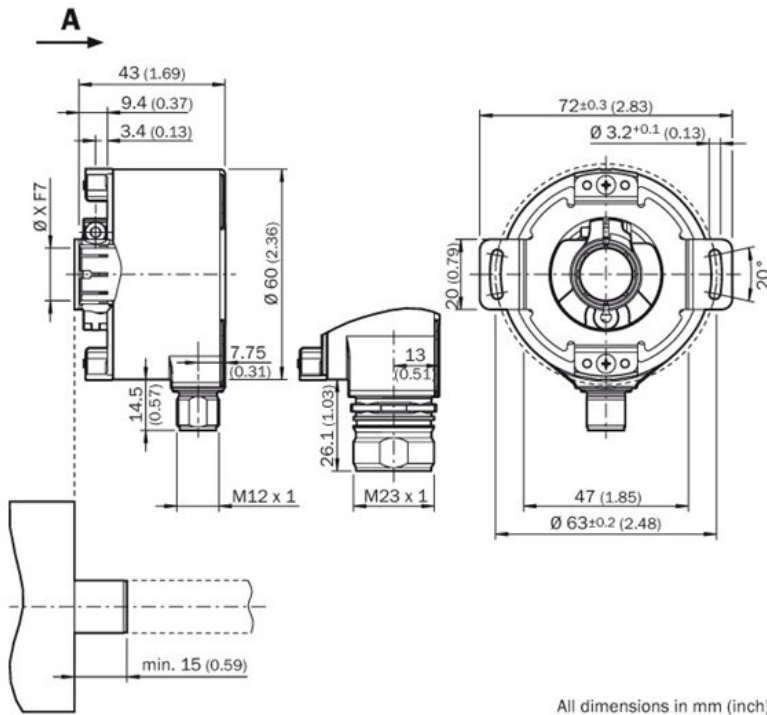

All dimensions in mm (inch)

Stator coupling

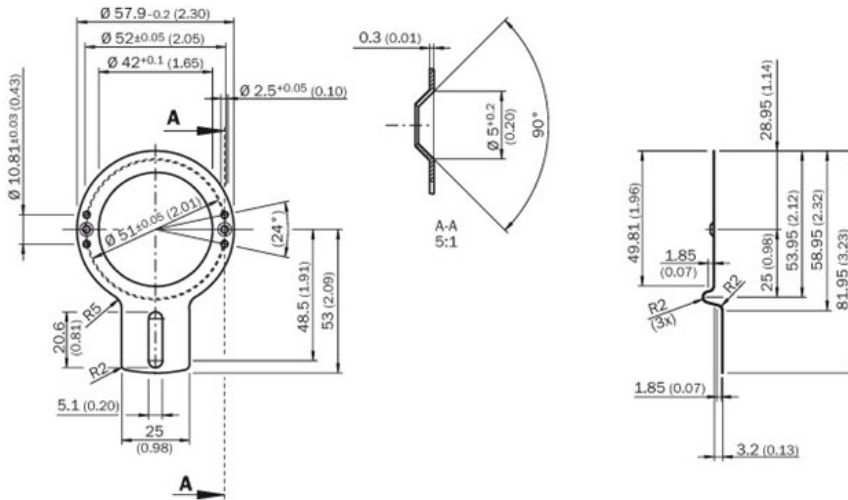

Australia

Phone +61 3 9457 0600
1800 334 802 – tollfree
E-Mail sales@sick.com.au

Belgium/Luxembourg

Phone +32 (0)2 466 55 66
E-Mail info@sick.be

Brasil

Phone +55 11 3215-4900
E-Mail sac@sick.com.br

Canada

Phone +1 905 771 14 44
E-Mail information@sick.com

Ceská Republika

Phone +420 2 57 91 18 50
E-Mail sick@sick.cz

China

Phone +86 4000 121 000
E-Mail info.china@sick.net.cn
Phone +852-2153 6300
E-Mail ghk@sick.com.hk

Danmark

Phone +45 45 82 64 00
E-Mail sick@sick.dk

Deutschland

Phone +49 211 5301-301
E-Mail kundenservice@sick.de

España

Phone +34 93 480 31 00
E-Mail info@sick.es

France

Phone +33 1 64 62 35 00
E-Mail info@sick.fr

Great Britain

Phone +44 (0)1727 831121
E-Mail info@sick.co.uk

India

Phone +91-22-4033 8333
E-Mail info@sick-india.com

Israel

Phone +972-4-6801000
E-Mail info@sick-sensors.com

Italia

Phone +39 02 27 43 41
E-Mail info@sick.it

Japan

Phone +81 (0)3 3358 1341
E-Mail support@sick.jp

Magyarország

Phone +36 1 371 2680
E-Mail office@sick.hu

Nederlands

Phone +31 (0)30 229 25 44
E-Mail info@sick.nl

Norge

Phone +47 67 81 50 00
E-Mail austefjord@sick.no

Österreich

Phone +43 (0)22 36 62 28 8-0
E-Mail office@sick.at

Polska

Phone +48 22 837 40 50
E-Mail info@sick.pl

România

Phone +40 356 171 120
E-Mail office@sick.ro

Russia

Phone +7-495-775-05-30
E-Mail info@sick.ru

Schweiz

Phone +41 41 619 29 39
E-Mail contact@sick.ch

Singapore

Phone +65 6744 3732
E-Mail admin@sicksgp.com.sg

Slovenija

Phone +386 (0)1-47 69 990
E-Mail office@sick.si

South Africa

Phone +27 11 472 3733
E-Mail info@sickautomation.co.za

South Korea

Phone +82 2 786 6321/4
E-Mail info@sickkorea.net

Suomi

Phone +358-9-25 15 800
E-Mail sick@sick.fi

Sverige

Phone +46 10 110 10 00
E-Mail info@sick.se

Taiwan

Phone +886-2-2375-6288
E-Mail sales@sick.com.tw

Türkiye

Phone +90 (216) 528 50 00
E-Mail info@sick.com.tr

United Arab Emirates

Phone +971 (0) 4 8865 878
E-Mail info@sick.ae

USA/México

Phone +1(952) 941-6780
1 800-325-7425 – tollfree
E-Mail info@sickusa.com

More representatives and agencies
at www.sick.com