



Vision sensors
LECTOR®65x, LECTOR®654 Dynamic Focus for
Systems

V2D654R-MEWHF6



Model Name > [V2D654R-MEWHF6](#)
Part No. > [1063229](#)



At a glance

- 2/4 megapixel resolution; high frame repetition rate of 40 Hz
- Dynamic focus adjustment from object to object
- Integrated high-power LED illumination
- Function buttons, aiming laser, optical and acoustic feedback signal
- Intelligent, rapid decoding algorithms

Your benefits

- Highly flexible code position, object height, and transport speed due to a large field of view and dynamic focus
- Cost-effective, straightforward, modular integration of multiple devices adapted to the width of the conveyor belt
- Minimum training and installation work due to intuitive device equipment that includes function buttons, auto setup, integrated illumination, an aiming laser, an acoustic feedback signal, and a green feedback LED
- Intelligent decoding algorithms ensure maximum reading performance and high package throughput, even with codes that are difficult to read
- SICK IDpro platform facilitates quick and easy integration into numerous industrial networks



Features

Sensor:	CMOS matrix sensor, gray scale values
Focus:	Dynamic focus control
Light source:	Lighting LEDs: white ($\lambda = 6000 \text{ K} \pm 500 \text{ K}$) feedback spot: visible green light ($\lambda = 525 \text{ nm} \pm 15 \text{ nm}$) aiming laser: visible red light ($\lambda = 630 \text{ nm} \dots 680 \text{ nm}$)
LED class:	Risk group 1 (IEC 62471 (2006-07) / EN 62471 (2008-09))
Reading field:	Side
Sensor resolution:	2,048 px x 2,048 px
Internal lighting:	White
Laser class:	1M (IEC 60825-1 (2007-3)), complies with 21 CFR 1040.10 except for the tolerance according to "Laser Notice No. 50" from June 24, 2007
Scanning frequency:	40 Hz, at 4 megapixels resolution
Code resolution:	$\geq 0.12 \text{ mm}^1$

¹⁾ Depends on distance

Performance

Bar code types:	Interleaved 2 of 5, Codabar, Code 128, Code 32, Code 39, Code 93, GS1 DataBar, GS1-128/EAN 128, Pharmacode, UPC/GTIN/EAN
2D code types:	Data Matrix ECC200, GS1 Data-Matrix, MaxiCode, PDF417, QR code
Internal image storage:	512 MB
Code qualification:	On the basis of ISO/IEC 16022, ISO/IEC 15415, ISO/IEC 18004

Interfaces

Configuration software:	SOPAS
Control elements:	2 buttons (choose and start/stop functions)
Serial (RS-232, RS-422):	0
USB:	0
Ethernet:	1
Function (Ethernet):	Host, AUX, image transmission
Data transmission rate (Ethernet):	10/100/1,000 Mbit/s
Protocol (Ethernet):	TCP/IP, FTP (image transmission), EtherNet/IP
CAN bus:	1
Function (CAN bus):	SICK CAN sensor network (Master/Slave, Multiplexer/Server)
Data transmission rate (CAN bus):	20 kbit/s ... 1 Mbit/s
Protocol (CAN bus):	CSN (SICK CAN Sensor Network)
PROFIBUS DP:	0
DeviceNet:	0
Switching inputs:	0
Switching outputs:	0
Reading pulse:	Auto pulse, CAN, Ethernet, Non-powered, Presentation mode, Switching inputs, Serial interface
Optical indicators:	21 LEDs (10 x status display, 10 x LED bar graph, 1 green feedback spot)
Acoustic indicators:	Beeper/buzzer (can be switched off, can be assigned a function to signal a result)
Memory card:	MicroSD memory card (flash card) max. 16 GB, optional

Mechanics/electronics

Power consumption:	Typ. 20 W, ± 20 %
Enclosure rating:	IP 65 (EN 60529 (1991-10), EN 60529/A2 (2002-02))
Weight:	963 g
Lens:	Integrated
Electrical connection:	1 x M12, 5-pin plug (CAN) 1 x M12, 5-pin socket (CAN) 1 x M8, 3-pin socket (external illumination) 2 x M12, 8-pin socket (Ethernet, P1 not yet with function)
Operating voltage:	24 V DC± 20 %
Housing:	Die-cast aluminum
Housing color:	Light blue (RAL 5012)
Protection class:	III
Dimensions:	142.6 mm x 90 mm x 106.1 mm

Ambient data

Electromagnetic compatibility (EMC):	EN 61000-6-2 (2005-08)/EN 61000-6-3 (2007-01)
Shock resistance:	EN 60068-2-6
Electrical safety:	EN 60950-1 (2011-01)
Ambient operating temperature:	0 °C ... 50 °C
Storage temperature:	-20 °C ... 70 °C
Permissible relative humidity:	90 %, non-condensing
Ambient light safety:	2,000 lx, on code

Dimensional drawing

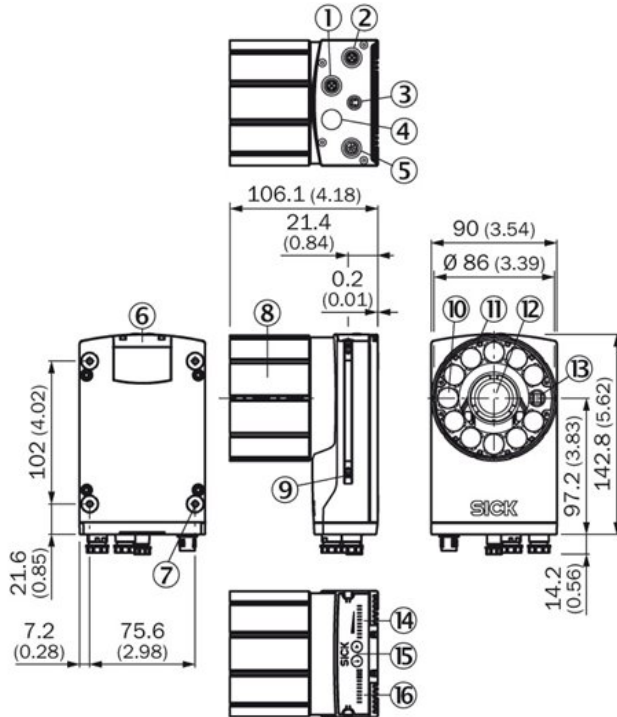

- [1] P1 connection, no function, planned "Ethernet", depending on type
- [2] P3 connection "Ethernet"
- [3] X2 "USB" connection or "trigger external lighting", depending on type
- [4] P2 connection "CAN OUT", depending on type
- [5] X1 "Power/Serial Data/CAN/I/O" connection or "CAN IN", depending on type
- [6] cover (flap) for the slot of the microSD memory card
- [7] blind hole thread M5, 5 mm deep (4 x), for mounting
- [8] lens protective cover
- [9] sliding nut M5, 5.5 mm deep (2 x), for mounting (as alternative)
- [10] green feedback LED
- [11] Ring light
- [12] Lens
- [13] outlet, aiming laser
- [14] Bar graph display
- [15] Function button (2 x)
- [16] LED for status display (2 levels), 10 x

Field of view

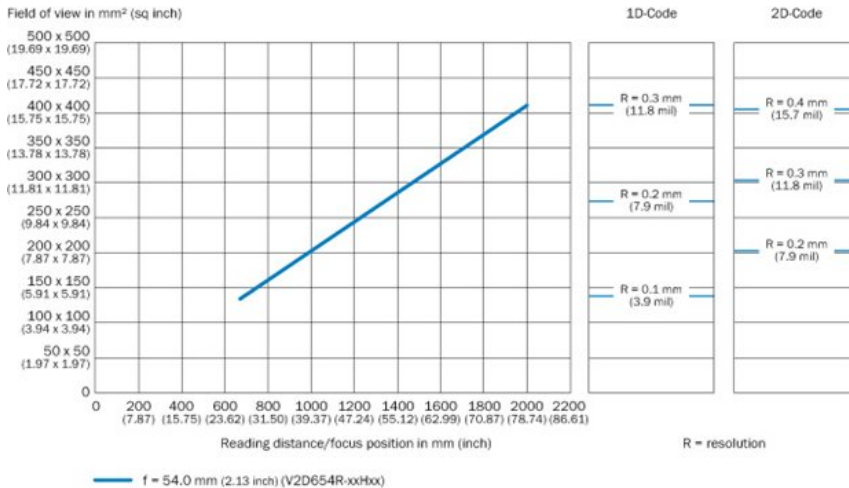

Australia

Phone +61 3 9457 0600
1800 334 802 – tollfree
E-Mail sales@sick.com.au

Belgium/Luxembourg

Phone +32 (0)2 466 55 66
E-Mail info@sick.be

Brasil

Phone +55 11 3215-4900
E-Mail sac@sick.com.br

Canada

Phone +1 905 771 14 44
E-Mail information@sick.com

Ceská Republika

Phone +420 2 57 91 18 50
E-Mail sick@sick.cz

China

Phone +86 4000 121 000
E-Mail info.china@sick.net.cn
Phone +852-2153 6300
E-Mail ghk@sick.com.hk

Danmark

Phone +45 45 82 64 00
E-Mail sick@sick.dk

Deutschland

Phone +49 211 5301-301
E-Mail kundenservice@sick.de

España

Phone +34 93 480 31 00
E-Mail info@sick.es

France

Phone +33 1 64 62 35 00
E-Mail info@sick.fr

Great Britain

Phone +44 (0)1727 831121
E-Mail info@sick.co.uk

India

Phone +91-22-4033 8333
E-Mail info@sick-india.com

Israel

Phone +972-4-6801000
E-Mail info@sick-sensors.com

Italia

Phone +39 02 27 43 41
E-Mail info@sick.it

Japan

Phone +81 (0)3 3358 1341
E-Mail support@sick.jp

Magyarország

Phone +36 1 371 2680
E-Mail office@sick.hu

Nederlands

Phone +31 (0)30 229 25 44
E-Mail info@sick.nl

Norge

Phone +47 67 81 50 00
E-Mail austefjord@sick.no

Österreich

Phone +43 (0)22 36 62 28 8-0
E-Mail office@sick.at

Polska

Phone +48 22 837 40 50
E-Mail info@sick.pl

România

Phone +40 356 171 120
E-Mail office@sick.ro

Russia

Phone +7-495-775-05-30
E-Mail info@sick.ru

Schweiz

Phone +41 41 619 29 39
E-Mail contact@sick.ch

Singapore

Phone +65 6744 3732
E-Mail admin@sicksgp.com.sg

Slovenija

Phone +386 (0)1-47 69 990
E-Mail office@sick.si

South Africa

Phone +27 11 472 3733
E-Mail info@sickautomation.co.za

South Korea

Phone +82 2 786 6321/4
E-Mail info@sickkorea.net

Suomi

Phone +358-9-25 15 800
E-Mail sick@sick.fi

Sverige

Phone +46 10 110 10 00
E-Mail info@sick.se

Taiwan

Phone +886-2-2375-6288
E-Mail sales@sick.com.tw

Türkiye

Phone +90 (216) 528 50 00
E-Mail info@sick.com.tr

United Arab Emirates

Phone +971 (0) 4 8865 878
E-Mail info@sick.ae

USA/México

Phone +1(952) 941-6780
1 800-325-7425 – tollfree
E-Mail info@sickusa.com

More representatives and agencies
at www.sick.com