

Main

Range compatibility	Lexium SD3
Product or component type	Motion control motor
Device short name	BRS3
Maximum mechanical speed	3000 rpm
Motor type	3-phase stepper motor
Number of motor poles	6
Supply voltage limits	34 V AC 48 V DC
Mounting support	Flange
Motor flange size	85 mm
Length	217 mm
Centring collar diameter	60 mm

Complementary

Centring collar depth	2 mm
Number of mounting holes	4
Mounting holes diameter	6.5 mm
Circle diameter of the mounting holes	98.99 mm
Electrical connection	Terminal box
Holding brake	With
Shaft end	Smooth shaft
Second shaft	Without second shaft end
Shaft diameter	14 mm
Shaft length	30 mm
Nominal torque	6 N.m
Holding torque	6.5 N.m
Rotor inertia	3.3 kg.cm ²
Resolution	1.8 °, 0.9 °, 0.72 °, 0.36 °, 0.18 °, 0.09 °, 0.072 °, 0.036 ° step angle

	200, 400, 500, 1000, 2000, 4000, 5000, 10000 steps number of full steps per revolution
Accuracy error	+/- 6 arc min
Maximum starting frequency	5.3 kHz
[In] rated current	5.8 A
Resistance	0.63 Ohm (winding)
Time constant	10 ms
Maximum radial force Fr	110 N (first shaft end) 75 N (second shaft end)
Maximum axial force Fa	175 N (tensile force) 30 N (force pressure)
Service life in hours	20000 h (bearing)
Angular acceleration	200000 rad/s ²
Product weight	4.3 kg

Environment

Standards	EN 50347 IEC 60072-1
Type of cooling	Natural convection
Ambient air temperature for operation	-25...40 °C
Ambient air temperature for storage	-25...70 °C
Operating altitude	<= 1000 m without power derating
Relative humidity	15...85 % without condensation
Vibration resistance	20 m/s ² maximum A conforming to EN/IEC 60034-14
IP degree of protection	IP56 total except shaft bushing: conforming to EN/IEC 60034-5 IP41 shaft bushing without shaft seal ring: conforming to EN/IEC 60034-5
Temperature class	F winding conforming to IEC/EN 60034-1

Offer Sustainability

Sustainable offer status	Green Premium product
REACH Regulation	REACH Declaration
REACH free of SVHC	Yes
EU RoHS Directive	Pro-active compliance (Product out of EU RoHS legal scope) EU RoHS Declaration
Mercury free	Yes
RoHS exemption information	Yes
China RoHS Regulation	China RoHS declaration
Environmental Disclosure	Product Environmental Profile
Circularity Profile	No need of specific recycling operations
WEEE	The product must be disposed on European Union markets following specific waste collection and never end up in rubbish bins

Contractual warranty

Warranty	18 months
----------	-----------

Dimensions

3-Phase Stepper Motor in Terminal Box Version

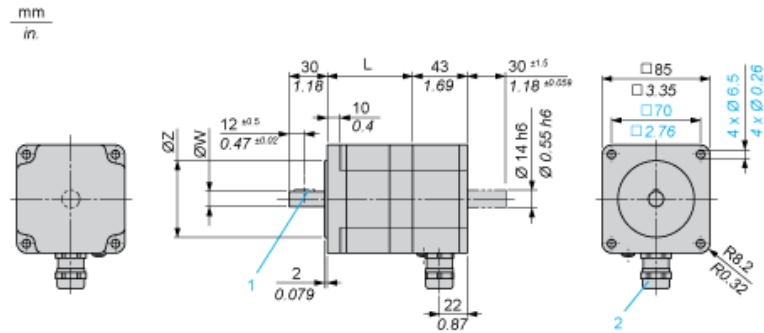

Holding Brake

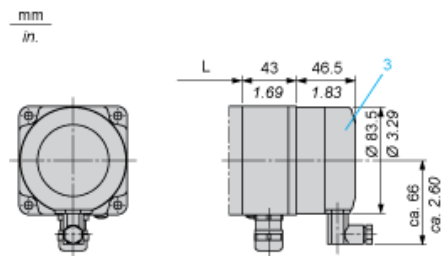

3 : Holding brake (optional)

Dimensions in mm

L	Shaft diameter ØW	Centring collar ØZ	Woodruff key DIN 6888 (1)	Cable gland (2)
127.5 (+0.6) (-0.8)	14 h6	60 h8	5 x 6.5	ISO M20 x 1.5

Dimensions in in.

L	Shaft diameter ØW	Centring collar ØZ	Woodruff key DIN 6888 (1)	Cable gland (2)
5.02 (+0.023) (-0.031)	0.55 h6	2.36 h8	0.20 x 0.25	ISO M20 x 1.5

Wiring Diagram of Holding Brake

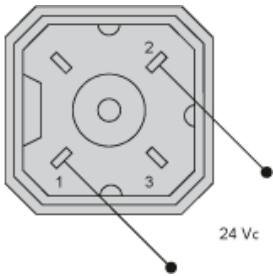

The connector is part of the scope of delivery. Connector designation: Hirschmann type G4 A 5M

Torque Characteristics

Measurement at 1000 Steps/Revolution, Nominal Voltage DC Bus U_N and Phase Current I_N

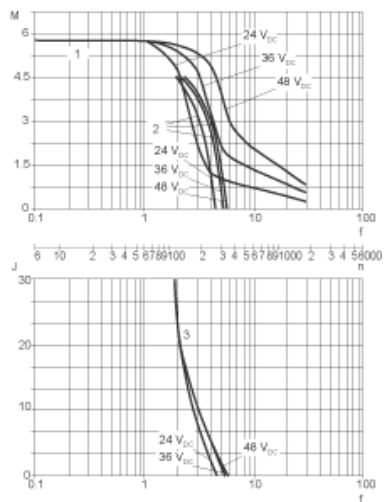

- M : Torque in Nm
- n : Speed in rpm
- f : Frequency in kHz
- J : Rotor inertia in kg.cm²
- 1 : Pull-out torque
- 2 : Pull-in torque
- 3 : Maximum load inertia