

# E11605



## Connection cable

VDOAH032MSS0010H03STGF030MSS

Status Archive

EVC250

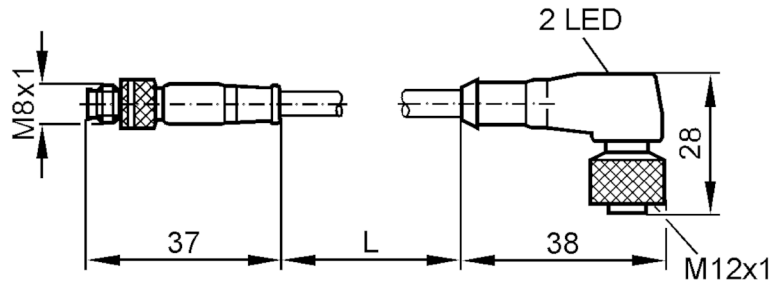

Application		
Free from silicone	yes	
Electrical data		
Operating voltage [V]	10...30 DC	
Protection class	III	
Max. current load total [A]	3	
Outputs		
Electrical design	PNP	
Operating conditions		
Ambient temperature [°C]	-25...85	
Protection	IP 68	
Mechanical data		
Weight [g]	244.2	
Materials	PUR	
Material nut	brass / brass	
Displays / operating elements		
Display	switching status	1 x LED, yellow
	operation	1 x LED, green
Remarks		
Pack quantity	1 pcs.	

# E11605



## Connection cable

VDOAH032MSS0010H03STGF030MSS

### Electrical connection

Cable: 10 m, PUR, Halogen-free, black, Ø 5 mm; 3 x 0.34 mm<sup>2</sup> (42 x Ø 0.1 mm )

### Electrical connection - socket

Connector: 1 x M12, angled; Moulded body: PUR; Locking: brass, nickel-plated; Contacts: gold-plated; Tightening torque: 0.7...0.9 Nm



### Electrical connection - plug

Connector: 1 x M8, straight; Moulded body: PUR; Locking: brass, nickel-plated; Contacts: gold-plated; Tightening torque: 0.6...0.7 Nm

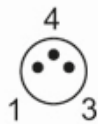

## Connection

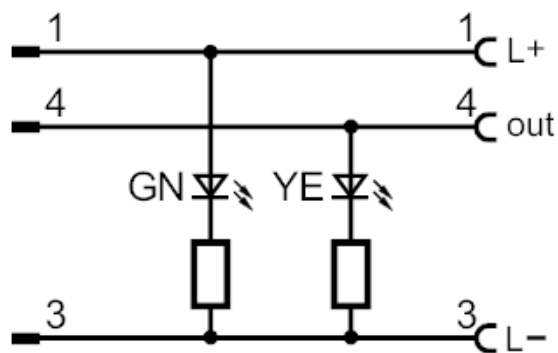

Status Archive

EVC250