

E30060

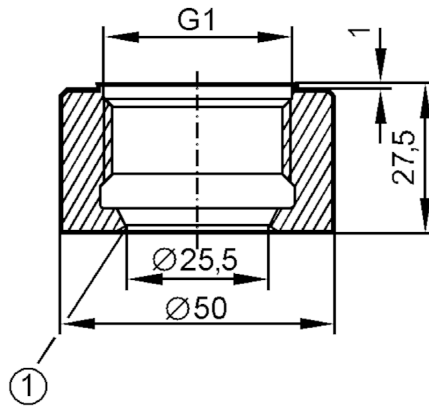

Welding adapter for process sensors

WELDING ADAPT G1 ST52-3



1 sealing edge

Application

Pressure rating [bar] 50

Mechanical data

Weight [g] 289.2

Materials steel (1.0570 / S355J2)

Surface characteristics Ra/Rz of the wetted parts 0.4 / 4

Remarks

Pack quantity 1 pcs.