

OG0035

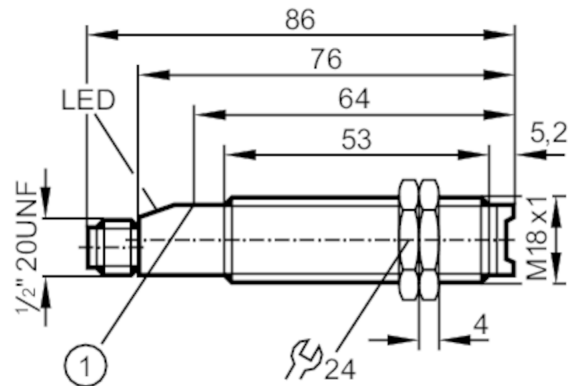

Diffuse reflection sensor

OGT-HBOA/LS-100-GK



1 pushbutton



Application

Function principle Diffuse reflection sensor

Electrical data

Frequency AC	[Hz]	47...63
Operating voltage	[V]	20...250 AC/DC
Protection class		II
Reverse polarity protection		no
Type of light		infrared light
Wave length	[nm]	880

Outputs

Output function		light-on mode
Max. voltage drop switching output DC	[V]	8
Max. voltage drop switching output AC	[V]	8
Minimum load current	[mA]	5
Max. leakage current	[mA]	1.7
Permanent current rating of switching output AC	[mA]	90; (180 (...40 °C))
Permanent current rating of switching output DC	[mA]	90; (180 (...40 °C))
Short-time current rating of switching output	[mA]	600; (20 ms / 0,5 Hz)
Switching frequency AC	[Hz]	25
Switching frequency DC	[Hz]	25
Short-circuit proof		no
Overload protection		no

OG0035



Diffuse reflection sensor

OGT-HBOA/LS-100-GK

Detection zone		
Range	[mm]	1...600; (white paper 200 x 200 mm 90 % remission)
Range adjustable		yes
Max. light spot diameter	[mm]	169
Light spot dimensions refer to		at maximum range
Operating conditions		
Ambient temperature	[°C]	-25...80
Protection		IP 67
Tests / approvals		
EMC	EN 60947-5-2	
	EN 55011	class B
MTTF	[years]	338
Mechanical data		
Weight	[g]	46
Housing		threaded type
Dimensions	[mm]	M18 x 1 / L = 76
Thread designation		M18 x 1
Materials		PBT
Lens material		PMMA
Displays / operating elements		
Display	switching status	1 x LED, red
	function	1 x LED, red flashing light
Electrical connection		
Required protection		miniature fuse to IEC60127-2 sheet 1; ≤ 2 A; fast acting
Accessories		
Accessories (supplied)		lock nuts: 2 x
Remarks		
Remarks		Recommendation: Check the safe functioning of the unit after a short circuit.
Pack quantity		1 pcs.
Electrical connection		
Connector: 1 x 1/2"		
		



Diffuse reflection sensor

OGT-HBOA/LS-100-GK

Connection

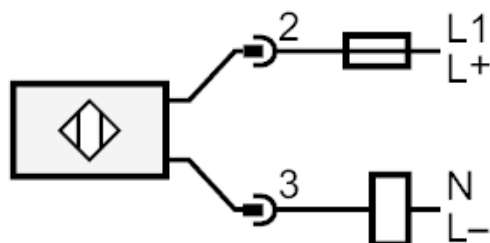

Note : miniature fuse to IEC60127-2 sheet 1 \leq 2 A fast acting

Diagrams and graphs

excess gain graph

