

E10200

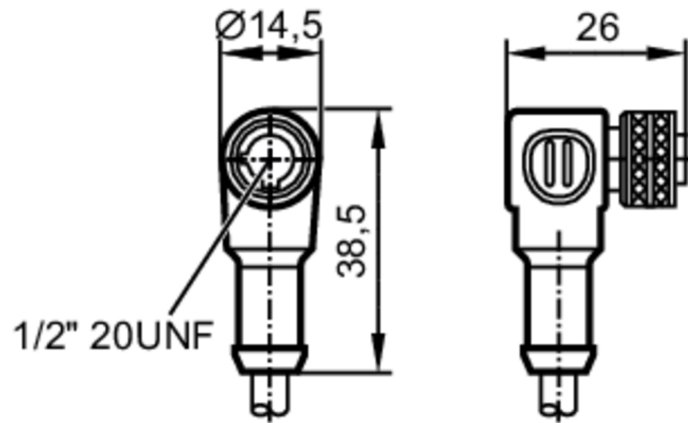

Connecting cable with socket

ADOAA030MSS0005E03



Electrical data		
Operating voltage	[V] < 250 AC / < 300 DC	
Operating conditions		
Ambient temperature	[°C] -25...90	
Protection	IP 67	
Mechanical data		
Weight	[g] 199	
Dimensions	[mm] 26 x 14.5 x 38.5	
Materials	TPU black	
Material nut	brass	
Drag chain suitability	bending radius for flexible use	min. 10 x cable diameter
	travel speed	max. 3.3 m/s for a horizontal travel length of 5 m and max. acceleration of 5 m/s ²
	bending cycles	> 2 Mio.
	torsional strain	± 180 °/m
Drag chain suitability	yes	
Remarks		
Pack quantity	1 pcs.	
Electrical connection		
Cable: 5 m, PVC, yellow, Ø 5.2 mm; 3 x (42 x Ø 0.1 mm) / AWG 22		
Electrical connection - socket		
Connector: 1 x 1/2", angled; Moulded body: TPU; Locking: brass, nickel-plated		

E10200



Connecting cable with socket

AD0AA030MSS0005E03



Connection

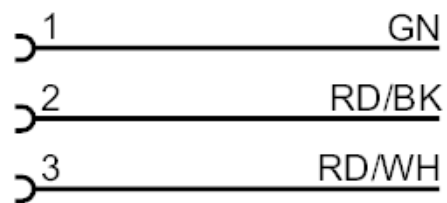

Core colours :

GN =

green

RD/BK =

red/black

RD/WH =

red/white