

E43212

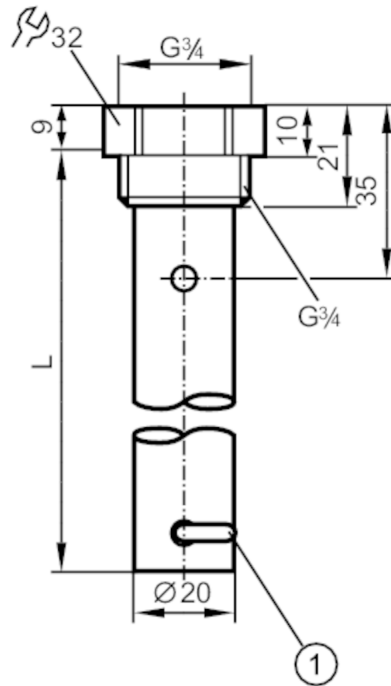

Coaxial pipe for level sensors

LR COAX TUBE 450 V2A



1 fixing bracket for centring piece

Application

Design	for level sensors LR
Medium temperature [°C]	-40...200
Tank pressure [bar]	-1...16

Mechanical data

Weight [g]	294.6
Materials	stainless steel (1.4301 / 304); Sealing: Tesnit; Centring piece: PPS glass fibre reinforced; fixing bracket: stainless steel (1.4310 / 301)
Sensor connection	G 3/4
Process connection	G 3/4
Length [mm]	450

Accessories

Accessories (supplied)	sealings: 1, Tesnit
------------------------	---------------------

Remarks

Pack quantity	1 pcs.
---------------	--------