

E11564

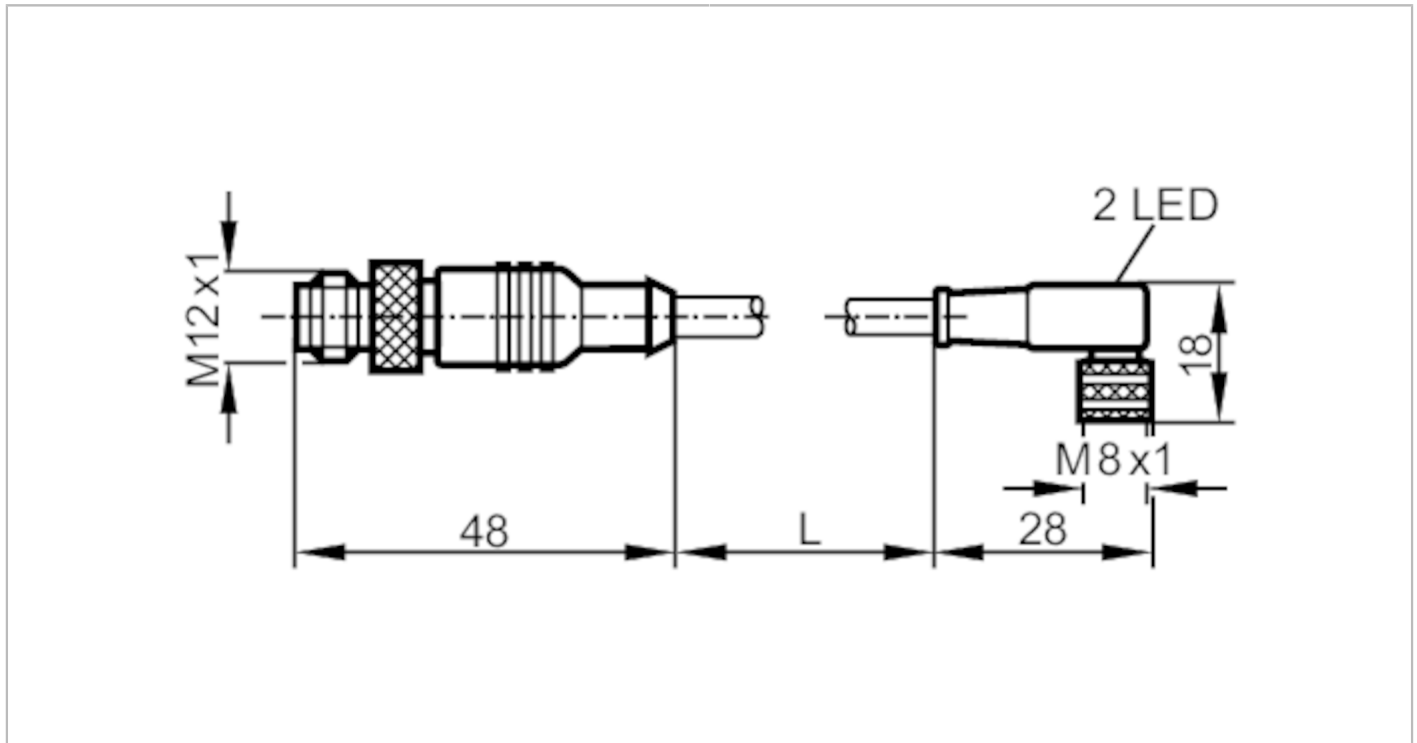

Connection cable

VDOAF032MSS01,5H03STGH030MSS



Application		
Free from silicone	yes	
Electrical data		
Operating voltage [V]	10...30 DC	
Protection class	III	
Max. current load total [A]	3	
Outputs		
Electrical design	PNP	
Operating conditions		
Ambient temperature [°C]	-25...85	
Protection	IP 68	
Mechanical data		
Weight [g]	55.2	
Materials	PUR	
Material nut	brass / brass	
Displays / operating elements		
Display	switching status	1 x LED, yellow
	operation	1 x LED, green
Remarks		
Pack quantity	1 pcs.	

E11564



Connection cable

VDOAF032MSS01,5H03STGH030MSS

Electrical connection

Cable: 1.5 m, PUR, Halogen-free, black, \varnothing 5 mm; 3 x 0.34 mm² (42 x \varnothing 0.1 mm)

Electrical connection - socket

Connector: 1 x M8, angled; Moulded body: PUR; Locking: brass, nickel-plated; Contacts: gold-plated; Tightening torque: 0.6...0.7 Nm



Electrical connection - plug

Connector: 1 x M12, straight; Moulded body: PUR; Locking: brass, nickel-plated; Contacts: gold-plated; Tightening torque: 0.7...0.9 Nm



Connection

