



Figure similar

SIRIUS soft starter 200-600 V 143 A, 110-250 V AC Spring-loaded terminals Analog output

**product brand name**

**product category**

**product designation**

**product type designation**

**manufacturer's article number**

- of standard HMI module usable
- of high feature HMI module usable
- of communication module PROFINET standard usable
- of communication module PROFIBUS usable
- of communication module Modbus TCP usable
- of communication module Modbus RTU usable
- of communication module Ethernet/IP
- of circuit breaker usable at 400 V
- of circuit breaker usable at 500 V
- of the gG fuse usable up to 690 V
- of full range R fuse link for semiconductor protection usable up to 690 V
- of back-up R fuse link for semiconductor protection usable up to 690 V
- of line contactor usable up to 480 V
- of line contactor usable up to 690 V

SIRIUS

Hybrid switching devices

Soft starter

3RW50

[3RW5980-OHS01](#)

[3RW5980-OHF00](#)

[3RW5980-OCS00](#)

[3RW5980-0CP00](#)

[3RW5980-0CT00](#)

[3RW5980-0CR00](#)

[3RW5980-0CE00](#)

[3VA2220-7MN32-0AA0](#); Type of assignment 1, Iq = 20 kA

[3VA2220-7MN32-0AA0](#); Type of assignment 1, Iq = 20 kA

[3NA3244-6](#); Type of coordination 1, Iq = 65 kA

[3NE1 227-0](#); Type of coordination 2, Iq = 65 kA

[3NE3 334 -0B](#); Type of coordination 2, Iq = 65 kA

[3RT1055](#)

[3RT1055](#)

**General technical data**

**starting voltage [%]**

30 ... 100 %

**stopping voltage [%]**

50 %; non-adjustable

**start-up ramp time of soft starter**

0 ... 20 s

**ramp-down time of soft starter**

0 ... 20 s

**current limiting value [%] adjustable**

130 ... 700 %

**accuracy class according to IEC 61557-12**

5 %

**certificate of suitability**

- CE marking Yes
- UL approval Yes
- CSA approval Yes

**product component**

- HMI-High Feature No
- is supported HMI-Standard Yes
- is supported HMI-High Feature Yes

**product feature integrated bypass contact system**

Yes

**number of controlled phases**

2

**trip class**

CLASS 10A / 10E (preset) / 20E; acc. to IEC 60947-4-2

**buffering time in the event of power failure**

<ul style="list-style-type: none"> <li>• for main current circuit</li> <li>• for control circuit</li> </ul>	100 ms
<b>insulation voltage rated value</b>	100 ms
<b>degree of pollution</b>	600 V
<b>impulse voltage rated value</b>	3, acc. to IEC 60947-4-2
<b>blocking voltage of the thyristor maximum</b>	6 kV
<b>service factor</b>	1 800 V
<b>surge voltage resistance rated value</b>	1
<b>maximum permissible voltage for safe isolation</b>	6 kV
<ul style="list-style-type: none"> <li>• between main and auxiliary circuit</li> </ul>	600 V
<b>shock resistance</b>	15 g / 11 ms, from 12 g / 11 ms with potential contact lifting
<b>vibration resistance</b>	15 mm to 6 Hz; 2g to 500 Hz
utilization category according to IEC 60947-4-2	AC-53a
<b>reference code according to IEC 81346-2</b>	Q
<b>Substance Prohibitance (Date)</b>	09/23/2019
<b>product function</b>	
<ul style="list-style-type: none"> <li>• ramp-up (soft starting)</li> <li>• ramp-down (soft stop)</li> <li>• Soft Torque</li> <li>• adjustable current limitation</li> <li>• pump ramp down</li> <li>• intrinsic device protection</li> <li>• motor overload protection</li> <li>• evaluation of thermistor motor protection</li> <li>• auto-RESET</li> <li>• manual RESET</li> <li>• remote reset</li> <li>• communication function</li> <li>• operating measured value display</li> <li>• error logbook</li> <li>• via software parameterizable</li> <li>• via software configurable</li> <li>• <b>PROFenergy</b></li> </ul>	Yes
<ul style="list-style-type: none"> <li>• voltage ramp</li> <li>• torque control</li> <li>• analog output</li> </ul>	Yes
	Yes
	Yes
	Yes
	Yes
	Yes
	Yes; Electronic motor overload protection
	No
	Yes
	Yes
	Yes; By turning off the control supply voltage
	Yes
	Yes; Only in conjunction with special accessories
	Yes; Only in conjunction with special accessories
	No
	Yes
	Yes; in connection with the PROFINET Standard communication module
	Yes
	No
	Yes; 4 ... 20 mA (default) / 0 ... 10 V (parameterizable with High Feature HMI)

## Power Electronics

<b>operational current</b>	
<ul style="list-style-type: none"> <li>• at 40 °C rated value</li> <li>• at 50 °C rated value</li> <li>• at 60 °C rated value</li> </ul>	143 A
<b>operating voltage</b>	128 A
<ul style="list-style-type: none"> <li>• rated value</li> </ul>	118 A
<b>relative negative tolerance of the operating voltage</b>	200 ... 600 V
<b>relative positive tolerance of the operating voltage</b>	-15 %
<b>operating power for 3-phase motors</b>	10 %
<ul style="list-style-type: none"> <li>• at 230 V at 40 °C rated value</li> <li>• at 400 V at 40 °C rated value</li> <li>• at 500 V at 40 °C rated value</li> </ul>	37 kW
<b>Operating frequency 1 rated value</b>	75 kW
<b>Operating frequency 2 rated value</b>	90 kW
<b>relative negative tolerance of the operating frequency</b>	50 Hz
<b>relative positive tolerance of the operating frequency</b>	60 Hz
<b>adjustable motor current</b>	-10 %
<ul style="list-style-type: none"> <li>• at rotary coding switch on switch position 1</li> <li>• at rotary coding switch on switch position 2</li> <li>• at rotary coding switch on switch position 3</li> <li>• at rotary coding switch on switch position 4</li> <li>• at rotary coding switch on switch position 5</li> <li>• at rotary coding switch on switch position 6</li> <li>• at rotary coding switch on switch position 7</li> <li>• at rotary coding switch on switch position 8</li> </ul>	10 %
	68 A
	73 A
	78 A
	83 A
	88 A
	93 A
	98 A
	103 A

<ul style="list-style-type: none"> <li>• at rotary coding switch on switch position 9</li> <li>• at rotary coding switch on switch position 10</li> <li>• at rotary coding switch on switch position 11</li> <li>• at rotary coding switch on switch position 12</li> <li>• at rotary coding switch on switch position 13</li> <li>• at rotary coding switch on switch position 14</li> <li>• at rotary coding switch on switch position 15</li> <li>• at rotary coding switch on switch position 16</li> <li>• minimum</li> </ul>	108 A
	113 A
	118 A
	123 A
	128 A
	133 A
	138 A
	143 A
	68 A
<b>minimum load [%]</b>	15 %; Relative to smallest settable I <sub>e</sub>
<b>power loss [W] for rated value of the current at AC</b>	
<ul style="list-style-type: none"> <li>• at 40 °C after startup</li> <li>• at 50 °C after startup</li> <li>• at 60 °C after startup</li> </ul>	23 W
	19 W
	16 W
<b>power loss [W] at AC at current limitation 350 %</b>	
<ul style="list-style-type: none"> <li>• at 40 °C during startup</li> <li>• at 50 °C during startup</li> <li>• at 60 °C during startup</li> </ul>	1 336 W
	1 134 W
	1 007 W
<b>type of the motor protection</b>	Electronic, tripping in the event of thermal overload of the motor
<b>Control circuit/ Control</b>	
<b>type of voltage of the control supply voltage</b>	AC
<b>control supply voltage at AC</b>	
<ul style="list-style-type: none"> <li>• at 50 Hz</li> <li>• at 60 Hz</li> </ul>	110 ... 250 V
	110 ... 250 V
<b>relative negative tolerance of the control supply voltage at AC at 50 Hz</b>	-15 %
<b>relative positive tolerance of the control supply voltage at AC at 50 Hz</b>	10 %
<b>relative negative tolerance of the control supply voltage at AC at 60 Hz</b>	-15 %
<b>relative positive tolerance of the control supply voltage at AC at 60 Hz</b>	10 %
<b>control supply voltage frequency</b>	50 ... 60 Hz
<b>relative negative tolerance of the control supply voltage frequency</b>	-10 %
<b>relative positive tolerance of the control supply voltage frequency</b>	10 %
<b>control supply current in standby mode rated value</b>	30 mA
<b>holding current in bypass operation rated value</b>	80 mA
<b>locked-rotor current at close of bypass contact maximum</b>	2.5 A
<b>inrush current peak at application of control supply voltage maximum</b>	12.2 A
<b>duration of inrush current peak at application of control supply voltage</b>	2.2 ms
<b>design of the overvoltage protection</b>	Varistor
<b>design of short-circuit protection for control circuit</b>	4 A gG fuse (I <sub>cu</sub> =1 kA), 6 A quick-acting fuse (I <sub>cu</sub> =1 kA), C1 miniature circuit breaker (I <sub>cu</sub> = 600 A), C6 miniature circuit breaker (I <sub>cu</sub> = 300 A); Is not part of scope of supply
<b>Inputs/ Outputs</b>	
<b>number of digital inputs</b>	1
<b>number of digital outputs</b>	3
<ul style="list-style-type: none"> <li>• not parameterizable</li> </ul>	2
<b>digital output version</b>	2 normally-open contacts (NO) / 1 changeover contact (CO)
<b>number of analog outputs</b>	1
<b>switching capacity current of the relay outputs</b>	
<ul style="list-style-type: none"> <li>• at AC-15 at 250 V rated value</li> <li>• at DC-13 at 24 V rated value</li> </ul>	3 A
	1 A
<b>Installation/ mounting/ dimensions</b>	
<b>mounting position</b>	with vertical mounting surface +/-90° rotatable, with vertical mounting surface +/- 22.5° tiltable to the front and back
<b>fastening method</b>	screw fixing
<b>height</b>	198 mm
<b>width</b>	120 mm
<b>depth</b>	249 mm

required spacing with side-by-side mounting	
<ul style="list-style-type: none"> <li>• forwards</li> <li>• backwards</li> <li>• upwards</li> <li>• downwards</li> <li>• at the side</li> </ul>	10 mm 0 mm 100 mm 75 mm 5 mm
<b>weight without packaging</b>	3.2 kg

**Connections/ Terminals**

<b>type of electrical connection</b>	
<ul style="list-style-type: none"> <li>• for main current circuit</li> <li>• for control circuit</li> </ul>	busbar connection spring-loaded terminals
<b>width of connection bar maximum</b>	25 mm
<b>type of connectable conductor cross-sections</b>	
<ul style="list-style-type: none"> <li>• for main contacts for box terminal using the front clamping point solid</li> </ul>	16 ... 120 mm <sup>2</sup>
<ul style="list-style-type: none"> <li>• for main contacts for box terminal using the front clamping point finely stranded with core end processing</li> </ul>	16 ... 120 mm <sup>2</sup>
<ul style="list-style-type: none"> <li>• for main contacts for box terminal using the front clamping point finely stranded without core end processing</li> </ul>	10 ... 120 mm <sup>2</sup>
<ul style="list-style-type: none"> <li>• for main contacts for box terminal using the front clamping point stranded</li> </ul>	16 ... 70 mm <sup>2</sup>
<ul style="list-style-type: none"> <li>• at AWG cables for main contacts for box terminal using the front clamping point</li> </ul>	6 ... 250 kcmil
<ul style="list-style-type: none"> <li>• for main contacts for box terminal using the back clamping point solid</li> </ul>	16 ... 120 mm <sup>2</sup>
<ul style="list-style-type: none"> <li>• at AWG cables for main contacts for box terminal using the back clamping point</li> </ul>	6 ... 250 kcmil
<ul style="list-style-type: none"> <li>• for main contacts for box terminal using both clamping points solid</li> </ul>	max. 1x 95 mm <sup>2</sup> , 1x 120 mm <sup>2</sup>
<ul style="list-style-type: none"> <li>• for main contacts for box terminal using both clamping points finely stranded with core end processing</li> </ul>	max. 1x 95 mm <sup>2</sup> , 1x 120 mm <sup>2</sup>
<ul style="list-style-type: none"> <li>• for main contacts for box terminal using both clamping points finely stranded without core end processing</li> </ul>	max. 1x 95 mm <sup>2</sup> , 1x 120 mm <sup>2</sup>
<ul style="list-style-type: none"> <li>• for main contacts for box terminal using both clamping points stranded</li> </ul>	max. 2x 120 mm <sup>2</sup>
<ul style="list-style-type: none"> <li>• for main contacts for box terminal using the back clamping point finely stranded with core end processing</li> </ul>	16 ... 120 mm <sup>2</sup>
<ul style="list-style-type: none"> <li>• for main contacts for box terminal using the back clamping point finely stranded without core end processing</li> </ul>	10 ... 120 mm <sup>2</sup>
<ul style="list-style-type: none"> <li>• for main contacts for box terminal using the back clamping point stranded</li> </ul>	16 ... 120 mm <sup>2</sup>
<b>type of connectable conductor cross-sections</b>	
<ul style="list-style-type: none"> <li>• at AWG cables for main current circuit solid</li> </ul>	4 ... 250 kcmil
<ul style="list-style-type: none"> <li>• for DIN cable lug for main contacts stranded</li> </ul>	16 ... 95 mm <sup>2</sup>
<ul style="list-style-type: none"> <li>• for DIN cable lug for main contacts finely stranded</li> </ul>	25 ... 120 mm <sup>2</sup>
<b>type of connectable conductor cross-sections</b>	
<ul style="list-style-type: none"> <li>• for control circuit solid</li> </ul>	2x (0.25 ... 1.5 mm <sup>2</sup> )
<ul style="list-style-type: none"> <li>• for control circuit finely stranded with core end processing</li> </ul>	2x (0.25 ... 1.5 mm <sup>2</sup> )
<ul style="list-style-type: none"> <li>• at AWG cables for control circuit solid</li> </ul>	2x (24 ... 16)
<ul style="list-style-type: none"> <li>• at AWG cables for control circuit finely stranded with core end processing</li> </ul>	2x (24 ... 16)
<b>wire length</b>	
<ul style="list-style-type: none"> <li>• between soft starter and motor maximum</li> </ul>	800 m
<ul style="list-style-type: none"> <li>• at the digital inputs at AC maximum</li> </ul>	1 000 m
<b>tightening torque</b>	
<ul style="list-style-type: none"> <li>• for main contacts with screw-type terminals</li> </ul>	10 ... 14 N·m
<ul style="list-style-type: none"> <li>• for auxiliary and control contacts with screw-type terminals</li> </ul>	0.8 ... 1.2 N·m
<b>tightening torque [lbf-in]</b>	
<ul style="list-style-type: none"> <li>• for main contacts with screw-type terminals</li> </ul>	89 ... 124 lbf-in
<ul style="list-style-type: none"> <li>• for auxiliary and control contacts with screw-type</li> </ul>	7 ... 10.3 lbf-in

terminals

**Ambient conditions**

installation altitude at height above sea level maximum	5 000 m; derating as of 1000 m, see Manual
<b>ambient temperature</b>	
<ul style="list-style-type: none"> <li>during operation</li> </ul>	-25 ... +60 °C; Please observe derating at temperatures of 40 °C or above
<ul style="list-style-type: none"> <li>during storage and transport</li> </ul>	-40 ... +80 °C
<b>environmental category</b>	
<ul style="list-style-type: none"> <li>during operation according to IEC 60721</li> </ul>	3K6 (no ice formation, only occasional condensation), 3C3 (no salt mist), 3S2 (sand must not get into the devices), 3M6
<ul style="list-style-type: none"> <li>during storage according to IEC 60721</li> </ul>	1K6 (only occasional condensation), 1C2 (no salt mist), 1S2 (sand must not get inside the devices), 1M4
<ul style="list-style-type: none"> <li>during transport according to IEC 60721</li> </ul>	2K2, 2C1, 2S1, 2M2 (max. fall height 0.3 m)
<b>EMC emitted interference</b>	acc. to IEC 60947-4-2: Class A

**Communication/ Protocol**

<b>communication module is supported</b>	
<ul style="list-style-type: none"> <li>PROFINET standard</li> </ul>	Yes
<ul style="list-style-type: none"> <li>EtherNet/IP</li> </ul>	Yes
<ul style="list-style-type: none"> <li>Modbus RTU</li> </ul>	Yes
<ul style="list-style-type: none"> <li>Modbus TCP</li> </ul>	Yes
<ul style="list-style-type: none"> <li>PROFIBUS</li> </ul>	Yes

**UL/CSA ratings**

<b>manufacturer's article number</b>	
<ul style="list-style-type: none"> <li><b>of circuit breaker</b> <ul style="list-style-type: none"> <li>— usable for Standard Faults at 460/480 V according to UL</li> </ul> </li> </ul>	Siemens type: 3VA5225, max. 250 A; Iq = 10 kA
<ul style="list-style-type: none"> <li><b>of the fuse</b> <ul style="list-style-type: none"> <li>— usable for Standard Faults up to 575/600 V according to UL</li> <li>— usable for High Faults up to 575/600 V according to UL</li> </ul> </li> </ul>	Type: Class RK5 / K5, max. 350 A; Iq = 10 kA Type: Class J, max. 350 A; Iq = 100 kA
<b>operating power [hp] for 3-phase motors</b>	
<ul style="list-style-type: none"> <li>at 200/208 V at 50 °C rated value</li> </ul>	40 hp
<ul style="list-style-type: none"> <li>at 220/230 V at 50 °C rated value</li> </ul>	40 hp
<ul style="list-style-type: none"> <li>at 460/480 V at 50 °C rated value</li> </ul>	100 hp
<ul style="list-style-type: none"> <li>at 575/600 V at 50 °C rated value</li> </ul>	125 hp

**Safety related data**

<b>protection class IP on the front according to IEC 60529</b>	IP00; IP20 with cover
<b>touch protection on the front according to IEC 60529</b>	finger-safe, for vertical contact from the front with cover

**ATEX**

<b>certificate of suitability</b>	
<ul style="list-style-type: none"> <li>ATEX</li> </ul>	Yes
<ul style="list-style-type: none"> <li>IECEX</li> </ul>	Yes
<b>hardware fault tolerance according to IEC 61508 relating to ATEX</b>	0
<b>PFDAvg with low demand rate according to IEC 61508 relating to ATEX</b>	0.09
<b>PFHD with high demand rate according to EN 62061 relating to ATEX</b>	9E-6 1/h
<b>Safety Integrity Level (SIL) according to IEC 61508 relating to ATEX</b>	SIL1
<b>T1 value for proof test interval or service life according to IEC 61508 relating to ATEX</b>	3 y

**Certificates/ approvals**

General Product Approval	For use in hazardous locations
--------------------------	--------------------------------



[Confirmation](#)



For use in hazardous locations

Declaration of Conformity

Test Certificates

Marine / Shipping



IECEX

[Explosion Protection Certificate](#)



EG-Konf.

[Type Test Certificates/Test Report](#)



ABS

Marine / Shipping

other



LRS



PRS

[Confirmation](#)

### Further information

Information- and Downloadcenter (Catalogs, Brochures,...)

<https://www.siemens.com/ic10>

Industry Mall (Online ordering system)

<https://mall.industry.siemens.com/mall/en/en/Catalog/product?mlfb=3RW5055-2AB15>

Cax online generator

<http://support.automation.siemens.com/WW/CAxorder/default.aspx?lang=en&mlfb=3RW5055-2AB15>

Service&Support (Manuals, Certificates, Characteristics, FAQs,...)

<https://support.industry.siemens.com/cs/ww/en/ps/3RW5055-2AB15>

Image database (product images, 2D dimension drawings, 3D models, device circuit diagrams, EPLAN macros, ...)

[http://www.automation.siemens.com/bilddb/cax\\_de.aspx?mlfb=3RW5055-2AB15&lang=en](http://www.automation.siemens.com/bilddb/cax_de.aspx?mlfb=3RW5055-2AB15&lang=en)

Characteristic: Tripping characteristics, I<sup>2</sup>t, Let-through current

<https://support.industry.siemens.com/cs/ww/en/ps/3RW5055-2AB15/char>

Characteristic: Installation altitude

<http://www.automation.siemens.com/bilddb/index.aspx?view=Search&mlfb=3RW5055-2AB15&objecttype=14&gridview=view1>

Simulation Tool for Soft Starters (STS)

<https://support.industry.siemens.com/cs/ww/en/view/101494917>

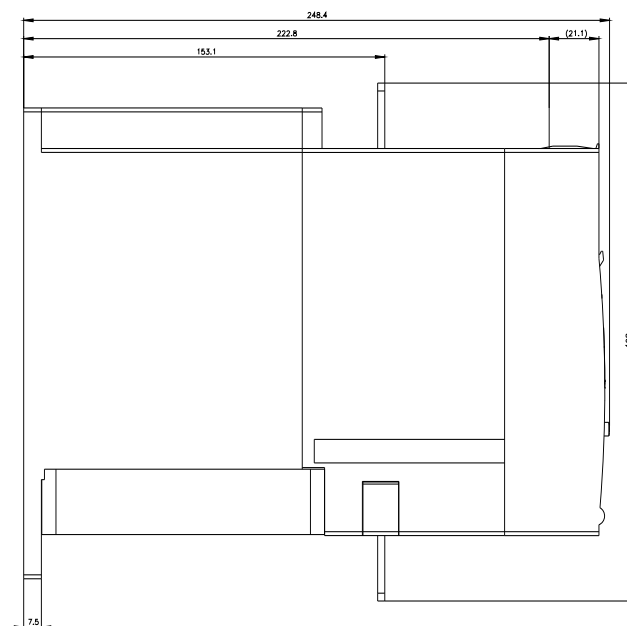
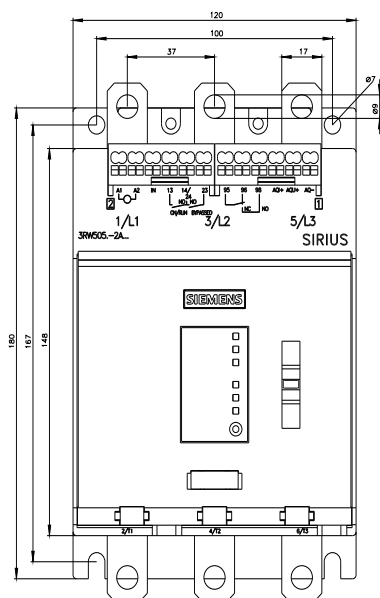

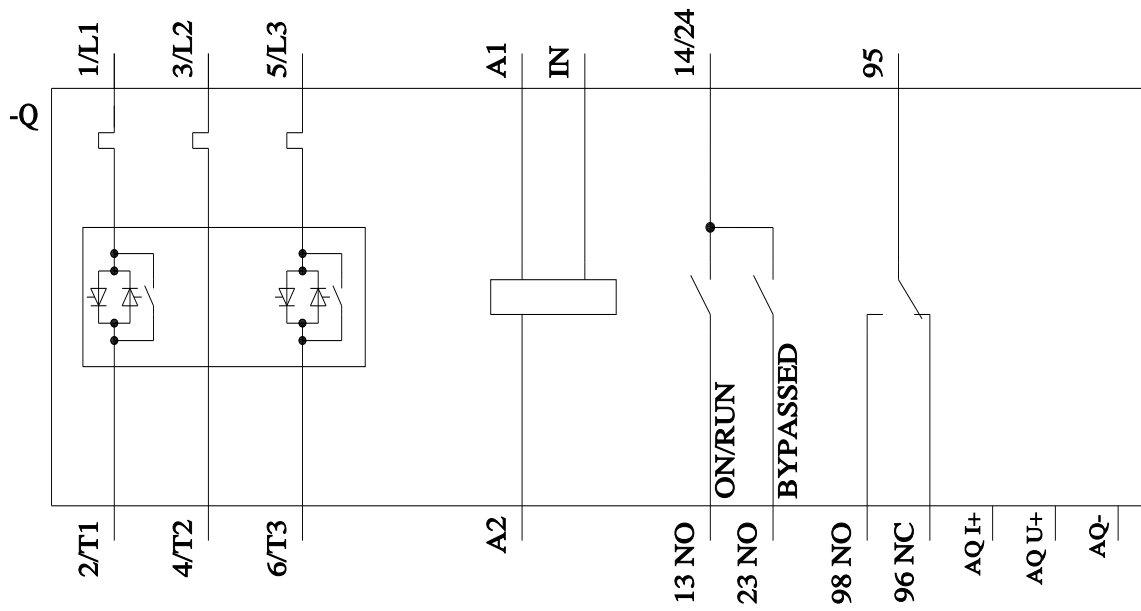

last modified:

4/11/2022 

