

# Submersible Pressure Sensor (Liquid Level)



## Datasheet

A 0 to 15 PSIG submersible pressure sensor (liquid level)

Submersible pressure transducers are commonly used to measure the level of liquid in large tanks using hydrostatic pressure. The height of the liquid above the position in the tank is referenced to atmospheric pressure through a vented cable. The sensing element is protected from damage and clogging by a stainless steel housing with a diaphragm protector. This device is powered by 10 V DC to 33 V DC and is well-suited for wastewater, slurry, sump, reservoirs, and most storage tank applications.

## Models

Model	Description	Connection
BWA-PRESSURE-SENSOR-15L	Includes one PS15G60S 0–15 psi pressure sensor gauge with a 1/4"-18 NPT port and one protective cage	2-wire flying leads with vent, 60 ft

Figure 1. Dimensions

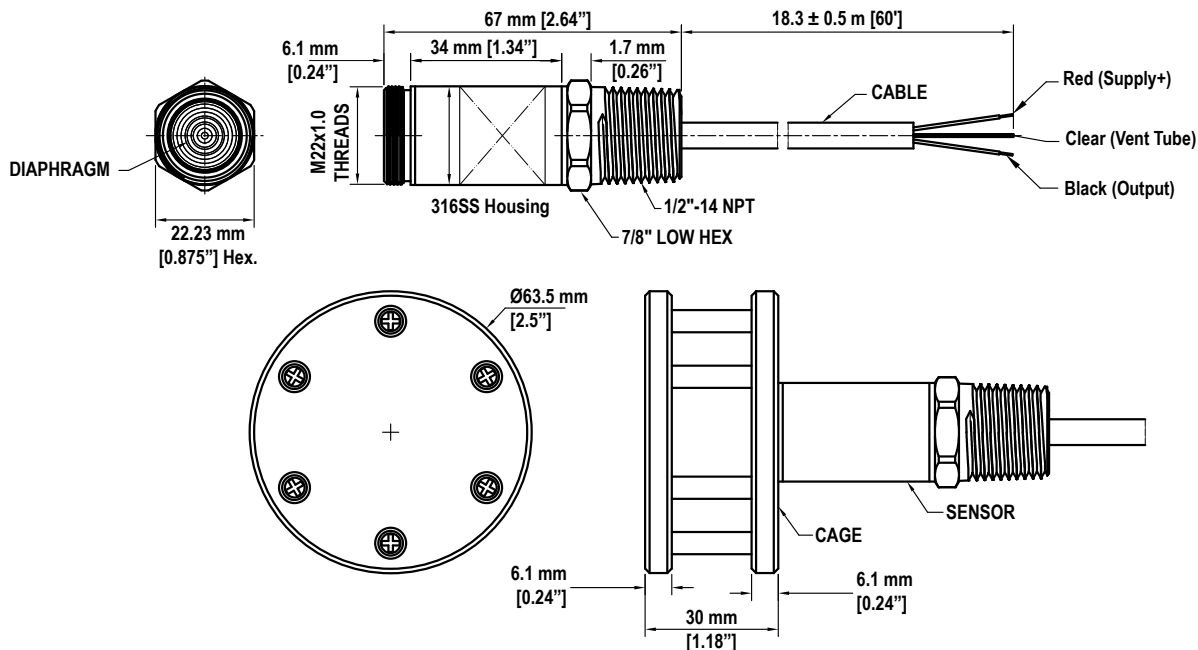

## Specifications

**Supply Voltage**  
10 V DC to 33 V DC

**Current Consumption**  
< 24 mA

**Pressure Range**  
0 to 15 PSI(G)  
Proof pressure: 2x full scale  
Burst pressure: 3x full scale

**Output**  
4 to 20 mA

**Accuracy**  
± 1% BFSL

**Stability**  
± 0.25% per year

**Temperature**  
Compensated: 0 °C to +55 °C (+32 °F to +131 °F)  
Operating: -40 °C to +85 °C (-40 °F to +185 °F)

**Tolerance**  
Zero Offset: ± 1%  
Span: ± 1.5%

**Fatigue Life**  
> 4 million cycles

**Connection**  
M22 x 1 port

**Composition**  
Housing: 316 stainless steel  
Wetted material: 316 stainless steel and PVC

**Environmental Rating**  
IEC IP68



## Banner Engineering Corp. Limited Warranty

---

Banner Engineering Corp. warrants its products to be free from defects in material and workmanship for one year following the date of shipment. Banner Engineering Corp. will repair or replace, free of charge, any product of its manufacture which, at the time it is returned to the factory, is found to have been defective during the warranty period. This warranty does not cover damage or liability for misuse, abuse, or the improper application or installation of the Banner product.

**THIS LIMITED WARRANTY IS EXCLUSIVE AND IN LIEU OF ALL OTHER WARRANTIES WHETHER EXPRESS OR IMPLIED (INCLUDING, WITHOUT LIMITATION, ANY WARRANTY OF MERCHANTABILITY OR FITNESS FOR A PARTICULAR PURPOSE), AND WHETHER ARISING UNDER COURSE OF PERFORMANCE, COURSE OF DEALING OR TRADE USAGE.**

This Warranty is exclusive and limited to repair or, at the discretion of Banner Engineering Corp., replacement. **IN NO EVENT SHALL BANNER ENGINEERING CORP. BE LIABLE TO BUYER OR ANY OTHER PERSON OR ENTITY FOR ANY EXTRA COSTS, EXPENSES, LOSSES, LOSS OF PROFITS, OR ANY INCIDENTAL, CONSEQUENTIAL OR SPECIAL DAMAGES RESULTING FROM ANY PRODUCT DEFECT OR FROM THE USE OR INABILITY TO USE THE PRODUCT, WHETHER ARISING IN CONTRACT OR WARRANTY, STATUTE, TORT, STRICT LIABILITY, NEGLIGENCE, OR OTHERWISE.**

Banner Engineering Corp. reserves the right to change, modify or improve the design of the product without assuming any obligations or liabilities relating to any product previously manufactured by Banner Engineering Corp. Any misuse, abuse, or improper application or installation of this product or use of the product for personal protection applications when the product is identified as not intended for such purposes will void the product warranty. Any modifications to this product without prior express approval by Banner Engineering Corp will void the product warranties. All specifications published in this document are subject to change; Banner reserves the right to modify product specifications or update documentation at any time. Specifications and product information in English supersede that which is provided in any other language. For the most recent version of any documentation, refer to: [www.bannerengineering.com](http://www.bannerengineering.com).

For patent information, see [www.bannerengineering.com/patents](http://www.bannerengineering.com/patents).