

ATV71E5D15N4

variable speed drive ATV71 - 15kW 20HP -
480V - EMC filter - IP54



Main

Range of product	Altivar 71
Product or component type	Variable speed drive
Product specific application	Complex, high-power machines
Component name	ATV71
Motor power kW	15 kW
Motor power hp	20 hp
Power supply voltage	380...480 V (- 15...10 %)
Network number of phases	3 phases
Line current	48 A for 380 V 39 A for 480 V
EMC filter	Class A EMC filter Integrated
Assembly style	Enclosed with Vario switch disconnecter
Variant	With EMC plate
Apparent power	31.6 kVA at 380 V
Maximum transient current	54.5 A for 2 s 49.5 A for 60 s
Speed drive output frequency	0...1600 Hz
Nominal switching frequency	4 kHz
Switching frequency	4...16 kHz with derating factor 1...16 kHz adjustable
Asynchronous motor control profile	ENA (Energy adaptation) system for unbalanced loads Flux vector control (FVC) with sensor (current vector) Sensorless flux vector control (SFVC) (voltage or current vector) Voltage/Frequency ratio (2 or 5 points)
Type of polarization	No impedance for Modbus

Complementary

Product destination	Asynchronous motors Synchronous motors
Power supply voltage limits	323...528 V
Power supply frequency	50...60 Hz +/- 5 %
Power supply frequency limits	47.5...63 Hz
Prospective line Isc	<= 22 kA
Continuous output current	33 A at 4 kHz 380 V 27 A at 4 kHz 460 V
Speed range	1...50 for synchronous motor in open-loop mode, without speed feedback 1...1000 for asynchronous motor in closed-loop mode with encoder feedback 1...100 for asynchronous motor in open-loop mode, without speed feedback
Speed accuracy	+/- 10 % of nominal slip for 0.2 Tn to Tn torque variation without speed feedback +/- 0.01 % of nominal speed for 0.2 Tn to Tn torque variation in closed-loop mode with encoder feedback
Torque accuracy	+/- 5 % in closed-loop mode with encoder feedback +/- 15 % in open-loop mode, without speed feedback
Transient overtorque	220 % of nominal motor torque +/- 10 % for 2 s 170 % of nominal motor torque +/- 10 % for 60 s

Braking torque	30 % without braking resistor ≤ 150 % with braking or hoist resistor
Synchronous motor control profile	Vector control without speed feedback
Regulation loop	Adjustable PI regulator
Motor slip compensation	Adjustable Automatic whatever the load Not available in voltage/frequency ratio (2 or 5 points) Suppressable
Diagnostic	1 LED red presence of drive voltage
Output voltage	≤ power supply voltage
Insulation	Electrical between power and control
Type of cable for mounting in an enclosure	Without mounting kit : 1-strand IEC cable at 45 °C, copper 90 °C XLPE/EPR Without mounting kit : 1-strand IEC cable at 45 °C, copper 70 °C PVC With NEMA Type 1 kit : 3-strand UL 508 cable at 40 °C, copper 75 °C PVC With an IP21 or an IP31 kit : 3-strand IEC cable at 40 °C, copper 70 °C PVC
Electrical connection	U/T1, V/T2, W/T3, PC/-, PO, PA/+, PA, PB terminal 35 mm ² / AWG 2 L1/R, L2/S, L3/T terminal 25 mm ² / AWG 2 AI1-/AI1+, AI2, AO1, R1A, R1B, R1C, R2A, R2B, LI1...LI6, PWR terminal 2.5 mm ² / AWG 14
Tightening torque	U/T1, V/T2, W/T3, PC/-, PO, PA/+, PA, PB 5.4 N.m / 47.7 lb.in L1/R, L2/S, L3/T 5.6 N.m / 50 lb.in AI1-/AI1+, AI2, AO1, R1A, R1B, R1C, R2A, R2B, LI1...LI6, PWR 0.6 N.m
Supply	Internal supply, 24 V DC, voltage limits 21...27 V, ≤ 200 mA for overload and short-circuit protection Internal supply for reference potentiometer (1 to 10 kOhm), 10.5 V DC +/- 5 %, ≤ 10 mA for overload and short-circuit protection
Analogue input number	2
Analogue input type	AI2 software-configurable voltage 0...10 V DC, impedance 30000 Ohm, resolution 11 bits AI2 software-configurable current 0...20 mA, impedance 242 Ohm, resolution 11 bits AI1-/AI1+ bipolar differential voltage +/- 10 V DC, resolution 11 bits + sign
Input sampling time	LI6 (if configured as logic input) 2 ms, +/- 0.5 ms for discrete input(s) LI1...LI5 2 ms, +/- 0.5 ms for discrete input(s) AI2 2 ms, +/- 0.5 ms for analog input(s) AI1-/AI1+ 2 ms, +/- 0.5 ms for analog input(s)
Response time	R2A, R2B 7 ms, tolerance +/- 0.5 ms for discrete output(s) R1A, R1B, R1C 7 ms, tolerance +/- 0.5 ms for discrete output(s) AO1 2 ms, tolerance +/- 0.5 ms for analog output(s) ≤ 100 ms in STO (Safe Torque Off)
Absolute accuracy precision	AO1 +/- 1 % for a temperature variation 60 °C AI2 +/- 0.6 % for a temperature variation 60 °C AI1-/AI1+ +/- 0.6 % for a temperature variation 60 °C
Linearity error	AO1 +/- 0.2 % AI1-/AI1+, AI2 +/- 0.15 % of maximum value
Analogue output number	1
Analogue output type	AO1 software-configurable voltage 0...10 V DC, impedance 470 Ohm AO1 software-configurable current 0...20 mA, impedance 500 Ohm AO1 software-configurable logic output 10 V ≤ 20 mA
Discrete output number	2
Discrete output type	R2A, R2B configurable relay logic NO, electrical durability 100000 cycles R1A, R1B, R1C configurable relay logic NO/NC, electrical durability 100000 cycles
Minimum switching current	Configurable relay logic 3 mA at 24 V DC
Maximum switching current	R1, R2 on resistive load, 5 A at 30 V DC, cos phi = 1, R1, R2 on resistive load, 5 A at 250 V AC, cos phi = 1, R1, R2 on inductive load, 2 A at 30 V DC, cos phi = 0.4, R1, R2 on inductive load, 2 A at 250 V AC, cos phi = 0.4,
Discrete input number	7
Discrete input type	PWR safety input 24 V DC, impedance 1500 Ohm LI6 switch-configurable PTC probe 0...6 probes, impedance 1500 Ohm LI6 switch-configurable 24 V DC, with level 1 PLC, impedance 3500 Ohm LI1...LI5 programmable 24 V DC, with level 1 PLC, impedance 3500 Ohm
Discrete input logic	LI6 (if configured as logic input) positive logic (source), < 5 V (state 0), > 11 V (state 1) LI6 (if configured as logic input) negative logic (sink), > 16 V (state 0), < 10 V (state 1) LI1...LI5 positive logic (source), < 5 V (state 0), > 11 V (state 1) LI1...LI5 negative logic (sink), > 16 V (state 0), < 10 V (state 1)

Acceleration and deceleration ramps	Automatic adaptation of ramp if braking capacity exceeded, by using resistor Linear adjustable separately from 0.01 to 9000 s S, U or customized
Braking to standstill	By DC injection
Protection type	Motor thermal protection Motor power removal Motor input phase breaks Drive thermal protection Drive short-circuit between motor phases Drive overvoltages on the DC bus Drive overheating protection Drive overcurrent between output phases and earth Drive line supply undervoltage Drive line supply overvoltage Drive input phase breaks Drive break on the control circuit Drive against input phase loss Drive against exceeding limit speed
Insulation resistance	> 1 mOhm at 500 V DC for 1 minute to earth
Frequency resolution	Display unit 0.1 Hz Analog input 0.024/50 Hz
Communication port protocol	CANopen Modbus
Type of connector	Male SUB-D 9 on RJ45 for CANopen 1 RJ45 for Modbus on terminal 1 RJ45 for Modbus on front face
Physical interface	2-wire RS 485 for Modbus
Transmission frame	RTU for Modbus
Transmission rate	20 kbps, 50 kbps, 125 kbps, 250 kbps, 500 kbps, 1 Mbps for CANopen 9600 bps, 19200 bps for Modbus on front face 4800 bps, 9600 bps, 19200 bps, 38.4 Kbps for Modbus on terminal
Data format	8 bits, odd even or no configurable parity for Modbus on terminal 8 bits, 1 stop, even parity for Modbus on front face
Number of addresses	1...247 for Modbus 1...127 for CANopen
Method of access	Slave for CANopen
Marking	CE
Operating position	Vertical +/- 10 degree
Height	665 mm
Width	315 mm
Depth	340 mm
Product weight	40.4 kg
Option card	Profibus DP V1 communication card Profibus DP communication card Overhead crane card Modbus/Uni-Telway communication card Modbus TCP communication card Modbus Plus communication card Interface card for encoder Interbus-S communication card I/O extension card Fipio communication card Ethernet/IP communication card DeviceNet communication card Controller inside programmable card CC-Link communication card

Environment

Noise level	60.2 dB conforming to 86/188/EEC
Dielectric strength	5092 V DC between control and power terminals 3535 V DC between earth and power terminals
Electromagnetic compatibility	Voltage dips and interruptions immunity test conforming to IEC 61000-4-11 Radiated radio-frequency electromagnetic field immunity test conforming to IEC 61000-4-3 level 3 Electrostatic discharge immunity test conforming to IEC 61000-4-2 level 3 Electrical fast transient/burst immunity test conforming to IEC 61000-4-4 level 4 Conducted radio-frequency immunity test conforming to IEC 61000-4-6 level 3 1.2/50 μ s - 8/20 μ s surge immunity test conforming to IEC 61000-4-5 level 3
Standards	EN 55011 class A group 2 EN 61800-3 environments 1 category C3 EN 61800-3 environments 2 category C3 EN/IEC 61800-3 EN/IEC 61800-5-1 IEC 60721-3-3 class 3C2 UL Type 12
Product certifications	CSA C-Tick GOST NOM 117 UL
Pollution degree	3 conforming to UL 840 2 conforming to EN/IEC 61800-5-1
IP degree of protection	IP54
Vibration resistance	1.5 mm peak to peak (f = 3...13 Hz) conforming to EN/IEC 60068-2-6 1 gn (f = 13...200 Hz) conforming to EN/IEC 60068-2-6
Shock resistance	15 gn for 11 ms conforming to EN/IEC 60068-2-27
Relative humidity	5...95 % without dripping water conforming to IEC 60068-2-3 5...95 % without condensation conforming to IEC 60068-2-3
Ambient air temperature for operation	-10...50 °C without derating
Ambient air temperature for storage	-25...70 °C
Operating altitude	1000...3000 m with current derating 1 % per 100 m <= 1000 m without derating

UL Type 12/IP 54 Drives with Vario

Dimensions

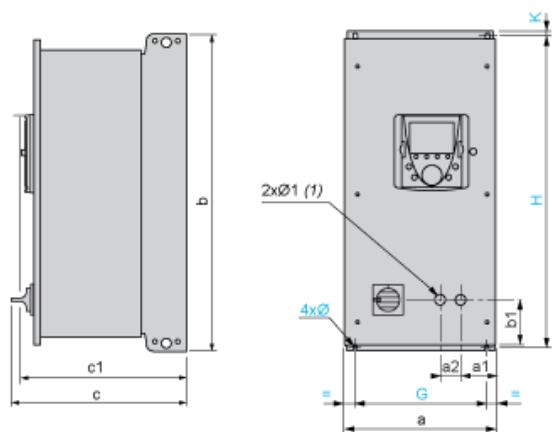

(1) The diameters and positions of the drill holes for mounting control and/or signalling units must be complied with. The customer is responsible for drilling and mounting units.

Dimensions in mm

a	a1	a2	b	b1	c	c1	G	H	K	Ø	Ø1
315	77	30	665	81	340	315	270	647	10	6	22.3

Dimensions in in.

a	a1	a2	b	b1	c	c1	G	H	K	Ø	Ø1
12.40	3.03	1.18	26.18	3.18	13.39	12.40	10.63	25.47	0.39	0.39	0.87

Mounting Recommendations

Depending on the conditions in which the drive is to be used, its installation will require certain precautions and the use of appropriate accessories. Install the unit vertically:

- Avoid placing it close to heating elements
- Leave sufficient free space to ensure that the air required for cooling purposes can circulate from the bottom to the top of the unit.

Clearance

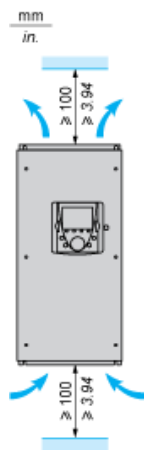

Mounting

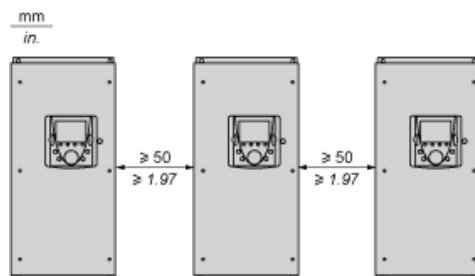

Wiring Diagram Conforming to Standards EN 954-1 Category 1, IEC/EN 61508 Capacity SIL1, in Stopping Category 0 According to IEC/EN 60204-1

Three-Phase Power Supply with Upstream Breaking via Contactor

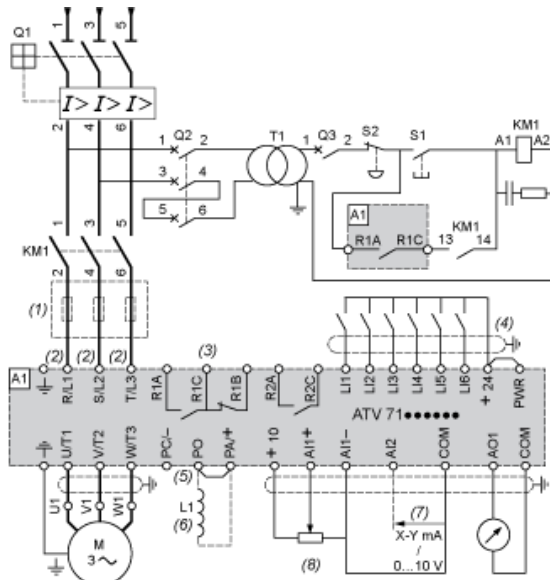

- A1 ATV71 drive
- KM1 Contactor
- L1 DC choke
- Q1 Circuit-breaker
- Q2 GV2 L rated at twice the nominal primary current of T1
- Q3 GB2CB05
- S1, XB4 B or XB5 A pushbuttons
- S2
- T1 100 VA transformer 220 V secondary
- (1) Line choke (three-phase); mandatory for ATV71HC11Y...HC63Y drives (except when a special transformer is used (12-pulse)).
- (2) For ATV71HC40N4 drives combined with a 400 kW motor, ATV71HC50N4 and ATV71HC40Y...HC63Y, refer to the power terminal connections diagram.
- (3) Fault relay contacts. Used for remote signalling of the drive status.
- (4) Connection of the common for the logic inputs depends on the positioning of the SW1 switch. The above diagram shows the internal power supply switched to the "source" position (for other connection types, refer to the user guide).
- (5) There is no PO terminal on ATV71HC11Y...HC63Y drives.
- (6) Optional DC choke for ATV71H...M3, ATV71HD11M3X...HD45M3X, ATV71•075N4...•D75N4 and ATV71P...N4Z drives. Connected in place of the strap between the PO and PA/+ terminals. For ATV71HD55M3X, HD75M3X, ATV71HD90N4...HC50N4 drives, the choke is supplied with the drive; the customer is responsible for connecting it.
- (7) Software-configurable current (0...20 mA) or voltage (0...10 V) analog input.
- (8) Reference potentiometer.

All terminals are located at the bottom of the drive. Fit interference suppressors on all inductive circuits near the drive or connected on the same circuit, such as relays, contactors, solenoid valves, fluorescent lighting, etc.

Wiring Diagram Conforming to Standards EN 954-1 Category 1, IEC/EN 61508 Capacity SIL1, in Stopping Category 0 According to IEC/EN 60204-1

Three-Phase Power Supply with Downstream Breaking via Switch Disconnecter

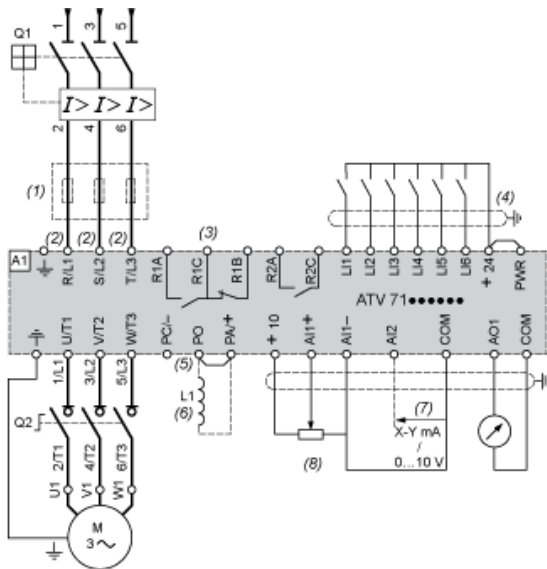

A1 ATV71 drive

L1 DC choke

Q1 Circuit-breaker

Q2 Switch disconnecter (Vario)

(1) Line choke (three-phase), mandatory for ATV71HC11Y...HC63Y drives (except when a special transformer is used (12-pulse)).

(2) For ATV71HC40N4 drives combined with a 400 kW motor, ATV71HC50N4 and ATV71HC40Y...HC63Y, refer to the power terminal connections diagram.

(3) Fault relay contacts. Used for remote signalling of the drive status.

(4) Connection of the common for the logic inputs depends on the positioning of the SW1 switch. The above diagram shows the internal power supply switched to the "source" position (for other connection types, refer to the user guide).

(5) There is no PO terminal on ATV71HC11Y...HC63Y drives.

(6) Optional DC choke for ATV71H...M3, ATV71HD11M3X...HD45M3X, ATV71•075N4...•D75N4 and ATV71P...N4Z drives. Connected in place of the strap between the PO and PA/+ terminals. For ATV71HD5M3X, HD75M3X, ATV71HD90N4...HC50N4 drives, the choke is supplied with the drive; the customer is responsible for connecting it.

(7) Software-configurable current (0...20 mA) or voltage (0...10 V) analog input.

(8) Reference potentiometer.

All terminals are located at the bottom of the drive. Fit interference suppressors on all inductive circuits near the drive or connected on the same circuit, such as relays, contactors, solenoid valves, fluorescent lighting, etc.

Wiring Diagram Conforming to Standards EN 954-1 Category 3, IEC/EN 61508 Capacity SIL2, in Stopping Category 0 According to IEC/EN 60204-1

Three-Phase Power Supply, Low Inertia Machine, Vertical Movement

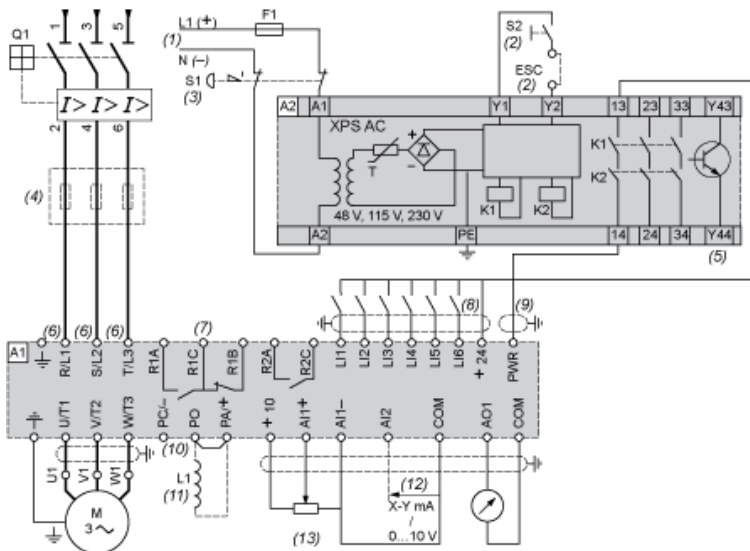

- A1 ATV71 drive
- A2 Preventa XPS AC safety module for monitoring emergency stops and switches. One safety module can manage the “Power Removal” function for several drives on the same machine. In this case, each drive must connect its PWR terminal to its + 24 V via the safety contacts on the XPS AC module. These contacts are independent for each drive.
- F1 Fuse
- L1 DC choke
- Q1 Circuit-breaker
- S1 Emergency stop button with 2 contacts
- S2 XB4 B or XB5 A pushbutton
- (1) Power supply: 24 Vdc or Vac, 48 Vac, 115 Vac, 230 Vac.
- (2) S2: resets XPS AC module on power-up or after an emergency stop. ESC can be used to set external starting conditions.
- (3) Requests freewheel stopping of the movement and activates the “Power Removal” safety function.
- (4) Line choke (three-phase), mandatory for and ATV71HC11Y...HC63Y drives (except when a special transformer is used (12-pulse)).
- (5) The logic output can be used to signal that the machine is in a safe stop state.
- (6) For ATV71HC40N4 drives combined with a 400 kW motor, ATV71HC50N4 and ATV71HC40Y...HC63Y, refer to the power terminal connections diagram.
- (7) Fault relay contacts. Used for remote signalling of the drive status.
- (8) Connection of the common for the logic inputs depends on the positioning of the SW1 switch. The above diagram shows the internal power supply switched to the “source” position (for other connection types, refer to the user guide).
- (9) Standardized coaxial cable, type RG174/U according to MIL-C17 or KX3B according to NF C 93-550, external diameter 2.54 mm / 0.09 in., maximum length 15 m / 49.21 ft. The cable shielding must be earthed.
- (10) There is no PO terminal on ATV71HC11Y...HC63Y drives.
- (11) Optional DC choke for ATV71H...M3, ATV71HD11M3X...HD45M3X, ATV71•075N4...•D75N4 and ATV71P...N4Z drives. Connected in place of the strap between the PO and PA/+ terminals. For ATV71HD55M3X, HD75M3X, ATV71HD90N4...HC50N4 drives, the choke is supplied with the drive; the customer is responsible for connecting it.
- (12) Software-configurable current (0...20 mA) or voltage (0...10 V) analog input.
- (13) Reference potentiometer.

All terminals are located at the bottom of the drive. Fit interference suppressors on all inductive circuits near the drive or connected on the same circuit, such as relays, contactors, solenoid valves, fluorescent lighting, etc.

Wiring Diagram Conforming to Standards EN 954-1 Category 3, IEC/EN 61508 Capacity SIL2, in Stopping Category 1 According to IEC/EN 60204-1

Three-Phase Power Supply, High Inertia Machine

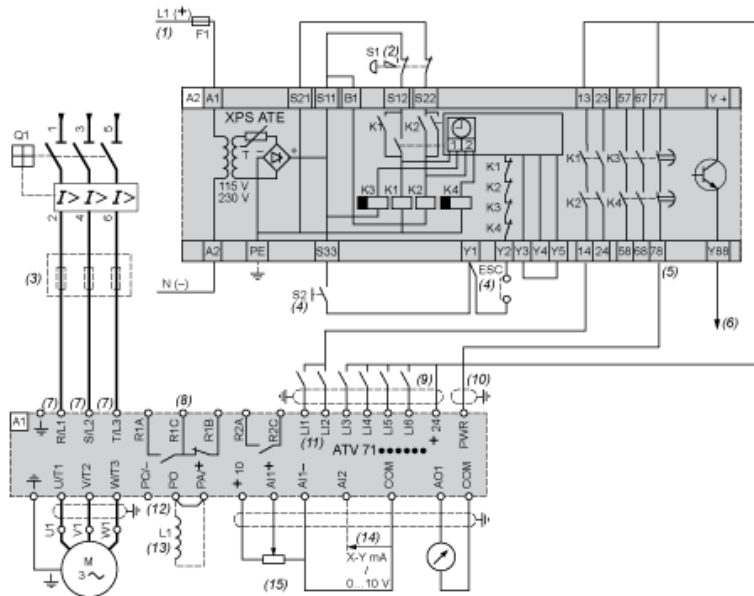

- A1 ATV71 drive
A2 Preventa XPS ATE safety module for monitoring emergency stops and switches. One safety module can manage the "Power Removal" safety function for several drives on the same machine. In this case the time delay must be adjusted on the drive controlling the motor that requires the longest stopping time. In addition, each drive must connect its PWR terminal to its + 24 V via the safety contacts on the XPS ATE module. These contacts are independent for each drive.
- F1 Fuse
L1 DC choke
Q1 Circuit-breaker
S1 Emergency stop button with 2 N/C contacts
S2 Run button
- (1) Power supply: 24 Vdc or Vac, 115 Vac, 230 Vac.
(2) Requests controlled stopping of the movement and activates the "Power Removal" safety function.
(3) Line choke (three-phase), mandatory for ATV71HC11Y...HC63Y drives (except when a special transformer is used (12-pulse)).
(4) S2: resets XPS ATE module on power-up or after an emergency stop. ESC can be used to set external starting conditions.
(5) For stopping times requiring more than 30 seconds in category 1, use a Preventa XPS AV safety module which can provide a maximum time delay of 300 seconds.
(6) The logic output can be used to signal that the machine is in a safe state.
(7) For ATV71HC40N4 drives combined with a 400 kW motor, ATV71HC50N4 and ATV71HC40Y...HC63Y, refer to the power terminal connections diagram.
(8) Fault relay contacts. Used for remote signalling of the drive status.
(9) Connection of the common for the logic inputs depends on the positioning of the SW1 switch. The above diagram shows the internal power supply switched to the "source" position (for other connection types, refer to the user guide).
(10) Standardized coaxial cable, type RG174/U according to MIL-C17 or KX3B according to NF C 93-550, external diameter 2.54 mm/0.09 in., maximum length 15 m/49.21 ft. The cable shielding must be earthed.
(11) Logic inputs LI1 and LI2 must be assigned to the direction of rotation: LI1 in the forward direction and LI2 in the reverse direction.
(12) There is no PO terminal on ATV71HC11Y...HC63Y drives.
(13) Optional DC choke for ATV71H...M3, ATV71HD11M3X...HD45M3X, ATV71•075N4...•D75N4 and ATV71P...•N4Z drives. Connected in place of the strap between the PO and PA/+ terminals. For ATV71HD55M3X, HD75M3X, ATV71HD90N4...HC50N4 drives, the choke is supplied with the drive; the customer is responsible for connecting it.
(14) Software-configurable current (0...20 mA) or voltage (0...10 V) analog input.
(15) Reference potentiometer.

All terminals are located at the bottom of the drive. Fit interference suppressors on all inductive circuits near the drive or connected on the same circuit, such as relays, contactors, solenoid valves, fluorescent lighting, etc.

Derating Curves

The derating curves for the drive nominal current (I_n) depend on the temperature and the switching frequency. For intermediate temperatures (e.g. 45°C), interpolate between 2 curves.

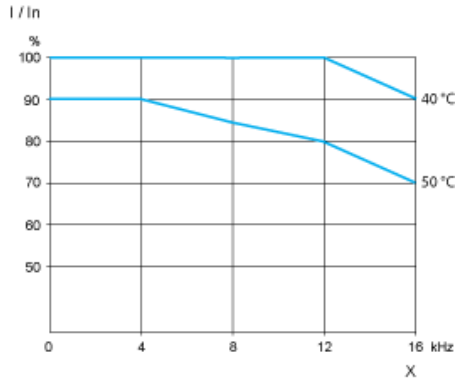

X Switching frequency