



## Main

|                              |   |
|------------------------------|---|
| Range of product             | Altivar 32                                |
| Product or component type    | Variable speed drive                      |
| Product destination          | Asynchronous motors<br>Synchronous motors |
| Product specific application | Complex machines                          |
| Function available           | -   |
| Assembly style               | With heat sink                            |
| Component name               | ATV32                                     |
| EMC filter                   | Class C2 EMC filter integrated            |
| Network number of phases     | 1 phase                                   |
| [Us] rated supply voltage    | 200...240 V - 15...10 %                   |
| Supply voltage limits        | 170...264 V                               |
| Supply frequency             | 50...60 Hz - 5...5 %                      |
| Network frequency limits     | 47.5...63 Hz                              |
| Motor power kW               | 0.37 kW 200...240 V                       |
| Motor power hp               | 0.5 hp 200...240 V                        |

## Complementary

|                                    |  |
|------------------------------------|--|
| Line current                       | 6 A 200 V 1 phase 0.37 kW 0.5 hp<br>5 A 240 V 1 phase 0.37 kW 0.5 hp   |
| Apparent power                     | 1.2 kVA 240 V 1 phase 0.37 kW 0.5 hp   |
| Prospective line I <sub>sc</sub>   | <= 1 kA 1 phase  |
| Nominal output current             | 3.3 A 4 kHz 240 V 0.37 kW 0.5 hp   |
| Maximum transient current          | 5 A 60 s 0.37 kW 0.5 hp  |
| Speed drive output frequency       | 0.5...599 Hz   |
| Nominal switching frequency        | 4 kHz  |
| Switching frequency                | 2...16 kHz adjustable  |
| Speed range                        | 1...100 asynchronous motor in open-loop mode   |
| Speed accuracy                     | +/- 10 % of nominal slip 0.2 T <sub>n</sub> to T <sub>n</sub>  |
| Torque accuracy                    | +/- 15 %   |
| Transient overtorque               | 170...200 %  |
| Braking torque                     | < 170 % with braking resistor  |
| Asynchronous motor control profile | Voltage/Frequency ratio, 2 points<br>Voltage/Frequency ratio, 5 points<br>Flux vector control without sensor - Energy Saving, NoLoad law<br>Flux vector control without sensor, standard<br>Voltage/Frequency ratio - Energy Saving, quadratic U/f |
| Synchronous motor control profile  | Vector control without sensor  |
| Regulation loop                    | Adjustable PID regulator   |
| Motor slip compensation            | Automatic whatever the load<br>Not available in voltage/frequency ratio (2 or 5 points)<br>Adjustable 0...300 %  |
| Local signalling                   | 1 LED red drive fault<br>1 LED red CANopen error<br>1 LED green CANopen run<br>1 LED red drive voltage   |
| Output voltage                     | <= power supply voltage  |

|                                     |   |
|-------------------------------------|---|
| Noise level                         | 43 dB 86/188/EEC  |
| Insulation                          | Electrical between power and control  |
| Electrical connection               | Screw terminal 1.5...4 mm <sup>2</sup> AWG 14...AWG 10 power supply<br>Removable screw terminals 1.5...2.5 mm <sup>2</sup> AWG 14...AWG 12 motor/braking resistor<br>Screw terminal 0.5...1.5 mm <sup>2</sup> AWG 18...AWG 14 control                       |
| Tightening torque                   | 0.6 N.m 5.3 lb/ft power supply<br>0.7 N.m 7.1 lb/ft motor/braking resistor<br>0.5 N.m 4.4 lb/ft control   |
| Supply                              | Internal supply for reference potentiometer (1 to 10 kOhm) 10.5 V DC +/- 5 % <= 10 mA overload and short-circuit protection   |
| Analogue input number               | 3   |
| Analogue input type                 | Current AI3 0...20 mA (or 4-20 mA, x-20 mA, 20-x mA or other patterns by configuration) 250 Ohm 10 bits<br>Bipolar differential voltage AI2 +/- 10 V DC 30000 Ohm 10 bits<br>Voltage AI1 0...10 V DC 30000 Ohm 10 bits                                      |
| Sampling duration                   | 2 ms AO1 analog<br>2 ms AI1, AI2, AI3 analog  |
| Response time                       | 2 ms R2A, R2C relay<br>2 ms R1A, R1B, R1C relay<br>8 ms +/- 0.7 ms LI1...LI6 logic  |
| Accuracy                            | +/- 2 % AO1 for a temperature of -10...60 °C<br>+/- 1 % AO1 for a temperature of 25 °C<br>+/- 0.5 % AI1, AI2, AI3 for a temperature of 25 °C<br>+/- 0.2 % AI1, AI2, AI3 for a temperature of -10...60 °C  |
| Linearity error                     | +/- 0.3 % AO1<br>+/- 0.2...0.5 % of maximum value AI1, AI2, AI3   |
| Analogue output number              | 1   |
| Analogue output type                | Software-configurable voltage AO1 0...10 V 470 Ohm 10 bits<br>Software-configurable current AO1 0...20 mA 800 Ohm 10 bits   |
| Discrete output number              | 3   |
| Discrete output type                | Logic LO<br>Configurable relay logic R2A, R2B NO 100000 cycles<br>Configurable relay logic R1A, R1B, R1C NO/NC 100000 cycles  |
| Minimum switching current           | 5 mA 24 V DC configurable relay logic   |
| Maximum switching current           | 5 A 30 V DC resistive cos phi = 1 R2<br>5 A 250 V AC resistive cos phi = 1 R2<br>2 A 30 V DC inductive cos phi = 0.4 R1, R2<br>2 A 250 V AC inductive cos phi = 0.4 R1, R2<br>4 A 30 V DC resistive cos phi = 1 R1<br>3 A 250 V AC resistive cos phi = 1 R1 |
| Discrete input number               | 7   |
| Discrete input type                 | Safe torque off STO 24...30 V DC 1500 Ohm<br>Switch-configurable PTC probe LI6 24...30 V DC<br>Programmable as pulse input 20 kpps LI5 24...30 V DC level 1 PLC<br>Programmable (sink/source) LI1...LI4 24...30 V DC level 1 PLC                            |
| Discrete input logic                | Positive logic (source) LI1...LI6 < 5 V > 11 V<br>Negative logic (sink) LI1...LI6 > 19 V < 13 V   |
| Acceleration and deceleration ramps | S<br>U<br>CUS<br>Deceleration ramp automatic stop DC injection<br>Deceleration ramp adaptation<br>Linear<br>Ramp switching  |
| Braking to standstill               | By DC injection   |
| Protection type                     | Thermal protection drive<br>Short-circuit between motor phases drive<br>Overheating protection drive<br>Overcurrent between output phases and earth drive<br>Input phase breaks drive   |
| Communication port protocol         | CANopen<br>Modbus   |
| Type of connector                   | 1 RJ45 Modbus/CANopen on front face   |
| Physical interface                  | 2-wire RS 485 Modbus  |
| Transmission frame                  | RTU Modbus  |
| Type of polarization                | No impedance Modbus   |

|                               |   |
|-------------------------------|---|
| Number of addresses           | 1...247 Modbus<br>1...127 CANopen   |
| Method of access              | Slave CANopen   |
| Electromagnetic compatibility | Voltage dips and interruptions immunity test IEC 61000-4-11<br>Radiated radio-frequency electromagnetic field immunity test level 3 IEC 61000-4-3<br>Electrostatic discharge immunity test level 3 IEC 61000-4-2<br>Electrical fast transient/burst immunity test level 4 IEC 61000-4-4<br>Conducted radio-frequency immunity test level 3 IEC 61000-4-6<br>1.2/50 µs - 8/20 µs surge immunity test level 3 IEC 61000-4-5 |
| Width                         | 45 mm   |
| Height                        | 325 mm  |
| Depth                         | 245 mm  |
| Product weight                | 2.4 kg  |
| Option card                   | Communication card Profibus DP V1<br>Communication card Ethernet/IP<br>Communication card DeviceNet<br>Communication card CANopen open style<br>Communication card CANopen daisy chain  |

## Environment

|                                       |  |
|---------------------------------------|--|
| Standards                             | EN 55011 class A group 1<br>EN 61800-3 environments 1 category C2<br>EN 61800-3 environments 2 category C2<br>EN/IEC 61800-3<br>EN/IEC 61800-5-1 |
| Product certifications                | CSA<br>C-Tick<br>GOST<br>NOM 117<br>UL   |
| Marking                               | CE   |
| Pollution degree                      | 2 EN/IEC 61800-5-1   |
| IP degree of protection               | IP20 EN/IEC 61800-5-1  |
| Vibration resistance                  | 1.5 mm peak to peak 3...13 Hz EN/IEC 60068-2-6<br>1 gn 13...200 Hz EN/IEC 60068-2-6  |
| Shock resistance                      | 15 gn 11 ms EN/IEC 60068-2-27  |
| Relative humidity                     | 5...95 % without dripping water IEC 60068-2-3<br>5...95 % without condensation IEC 60068-2-3   |
| Ambient air temperature for operation | 50...60 °C with derating factor<br>-10...50 °C without derating  |
| Ambient air temperature for storage   | -25...70 °C  |
| Operating altitude                    | 1000...2000 m with current derating 1 % per 100 m<br><= 1000 m without derating  |
| Operating position                    | Vertical +/- 10 degree   |

## Offer Sustainability

|                                  |   |
|----------------------------------|---|
| Sustainable offer status         | Not Green Premium product   |
| RoHS (date code: YYWW)           | Compliant - since 1007 - <a href="#">Schneider Electric declaration of conformity</a> |
| Product environmental profile    | Available <a href="#">Download Product Environmental</a>                              |
| Product end of life instructions | Available <a href="#">Download End Of Life Manual</a>                                 |

Size A

Dimensions

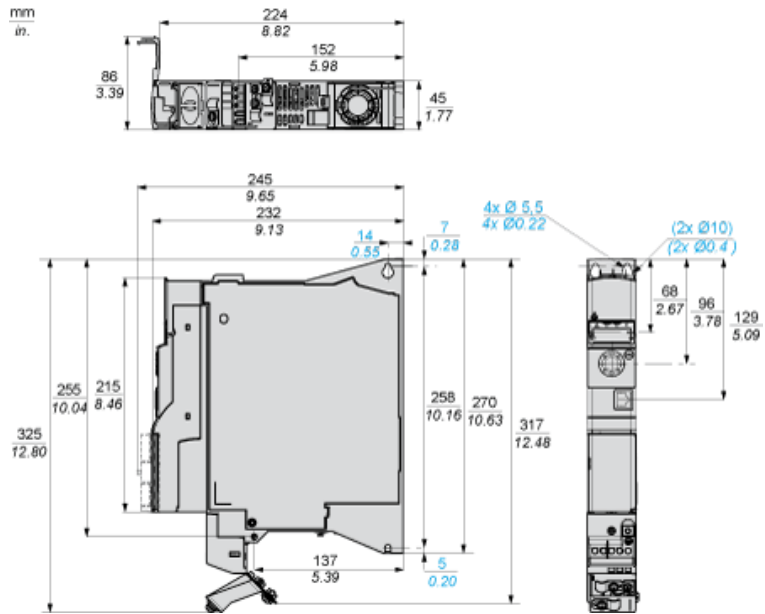

Mounting and Clearance

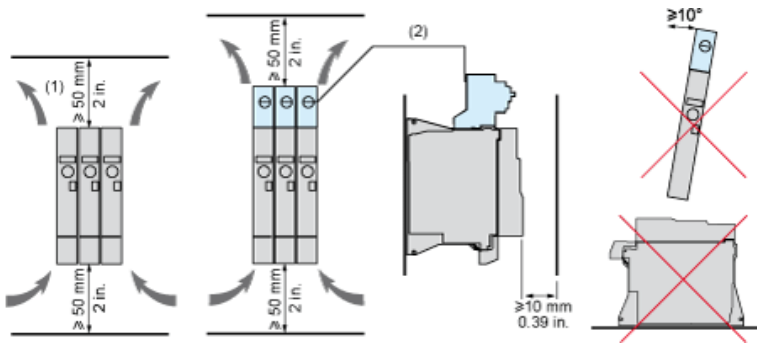

- (1) Minimum value corresponding to thermal constraints. A 150 mm clearance may help to connect the ground.
- (2) Optional GV2 circuit-breaker

Option: Protection Device, GV2 circuit-breaker

The drive is prepared to be equipped with an optional GV2 circuit-breaker.

The GV2 circuit-breaker is directly mounted on the drive. Mechanical and electrical link are made using the optional adapter. The options are supplied with detailed mounting instruction sheet.

NOTE: The product overall dimension, including GV2 adapter and EMC plate mounted, becomes 424 mm (16.7 in.)

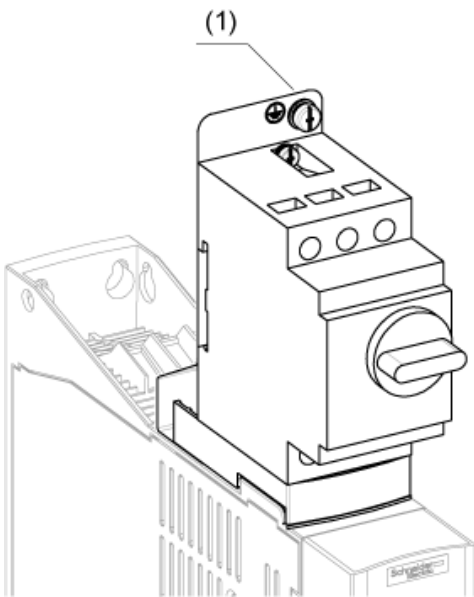

- (1) Ground screw (HS type 2 - 5x12)

Connection Diagrams

Single or Three-phase Power Supply - Diagram with Line Contactor

Connection diagrams conforming to standards EN 954-1 category 1 and IEC/EN 61508 capacity SIL1, stopping category 0 in accordance with standard IEC/EN 60204-1.



- (1) Line choke (if used)
- (3) Fault relay contacts, for remote signaling of drive status

Single or Three-phase Power Supply - Diagram with Switch Disconnect

Connection diagrams conforming to standards EN 954-1 category 1 and IEC/EN 61508 capacity SIL1, stopping category 0 in accordance with standard IEC/EN 60204-1.

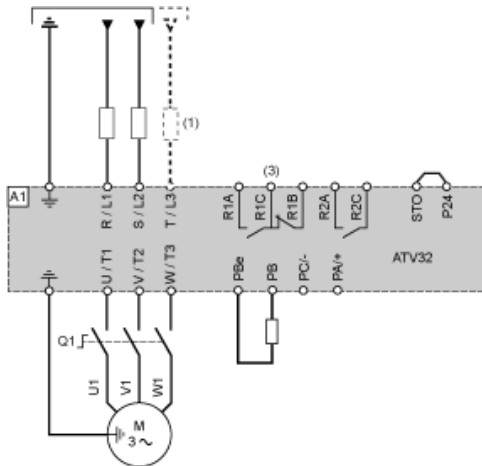

- (1) Line choke (if used)
- (3) Fault relay contacts, for remote signaling of drive status

Diagram with Preventa Safety Module (Safe Torque Off Function)

Connection diagrams conforming to standards EN 954-1 category 3 and IEC/EN 61508 capacity SIL2, stopping category 0 in accordance with standard IEC/EN 60204-1.

When the emergency stop is activated, the drive power supply is cut immediately and the motor stops in freewheel, according to category 0 of standard IEC/EN 60204-1.

A contact on the Preventa XPS AC module must be inserted in the brake control circuit to engage it safely when the STO (Safe Torque Off) safety function is activated.

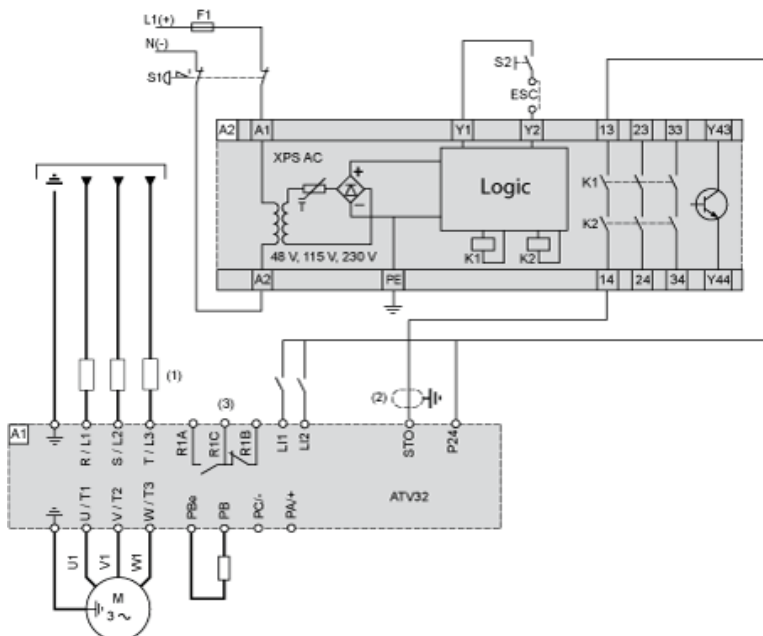

- (1) Line choke (if used)
- (2) It is essential to connect the shielding to the ground.
- (3) Fault relay contacts, for remote signaling of drive status

The STO safety function integrated into the product can be used to implement an "EMERGENCY STOP" (IEC 60204-1) for category 0 stops. With an additional, approved EMERGENCY STOP module, it is also possible to implement category 1 stops.

#### STO function

The STO safety function is triggered via 2 redundant inputs. The circuits of the two inputs must be separate so that there are always two channels. The switching process must be simultaneous for both inputs (offset < 1 s).

The power stage is disabled and an error message is generated. The motor can no longer generate torque and coasts down without braking. A restart is possible after resetting the error message with a "Fault Reset".

The power stage is disabled and an error message is generated if only one of the two inputs is switched off or if the time offset is too great. This error message can only be reset by switching off the product.

#### Diagram without Preventa Safety Module

Connection diagrams conforming to standards EN 954-1 category 2 and IEC/EN 61508 capacity SIL1, stopping category 0 in accordance with standard IEC/EN 60204-1.

The connection diagram below is suitable for use with machines with a short freewheel stop time (machines with low inertia or high resistive torque).

When the emergency stop is activated, the drive power supply is cut immediately and the motor stops in freewheel, according to category 0 of standard IEC/EN 60204-1.

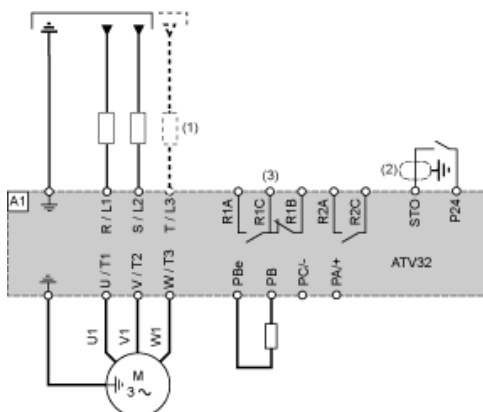

- (1) Line choke (if used)
- (2) It is essential to connect the shielding to the ground.
- (3) Fault relay contacts, for remote signaling of drive status

The STO safety function integrated into the product can be used to implement an "EMERGENCY STOP" (IEC 60204-1) for category 0 stops.

#### Control Connection Diagram in Source Mode

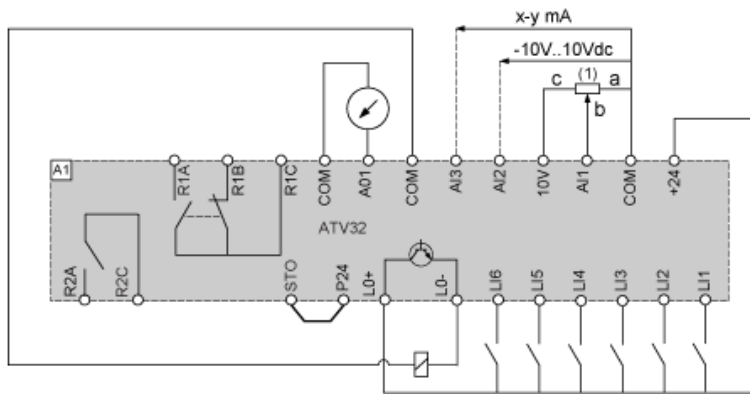

(1) Reference potentiometer SZ1RV1202 (2.2 kΩ) or similar (10 kΩ maximum)



Derating Curves

Derating curve for the nominal drive current ( $I_n$ ) as a function of temperature and switching frequency.

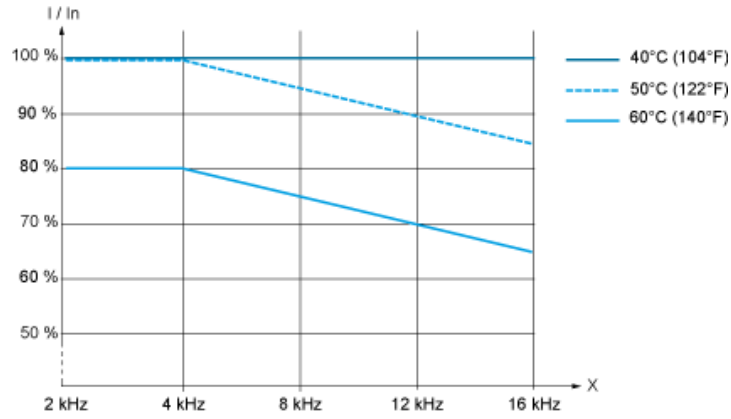

X Switching frequency

Above 4 kHz, the drive will reduce the switching frequency automatically in the event of an excessive temperature rise.

Sink / Source Switch Configuration (SW1)

The logic input switch (SW1) is used to adapt the operation of the logic inputs to the technology of the programmable controller outputs.

Switch SW1 set to "Source" position

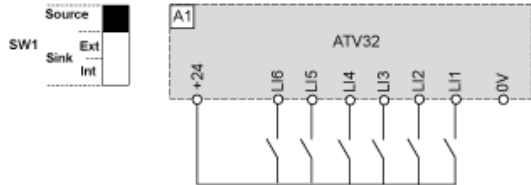

Switch SW1 set to "Source" position and use of an external power supply for the LIs

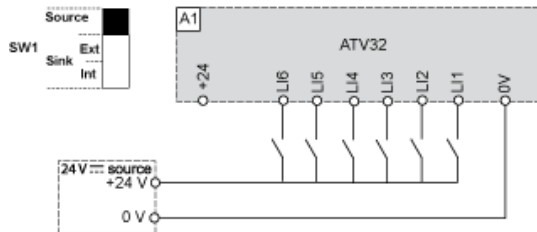

Switch SW1 set to "Sink Int" position

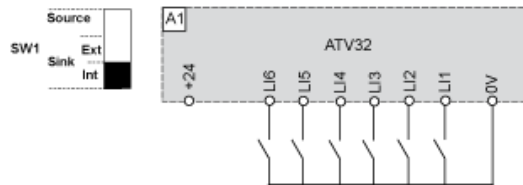

Switch SW1 set to "Sink Ext" position

