



## Main

Range of product	Harmony XAC
Product or component type	Contact block
Component name	XACS
Electrical circuit type	Control circuit
Contact block type	Single
Type of operator	Spring return
Product compatibility	XACA ZA2B... head
Mechanical interlocking	Without mechanical interlock
Contacts type and composition	1 NO
Mounting of block	Front mounting
Contacts operation	Slow-break

## Complementary

Connections - terminals	Screw clamp terminals, connection capacity: 2 x 1.5 mm <sup>2</sup> with or without cable end Screw clamp terminals, connection capacity: 1 x 2.5 mm <sup>2</sup> with or without cable end
Horizontal fixing centres	40 mm
Vertical fixing centres	30 mm
Mechanical durability	1000000 cycles
Contact code designation	Q300 DC-13, U <sub>e</sub> = 250 V, I <sub>e</sub> = 0.27 A conforming to IEC 60947-5-1 appendix A A300 AC-15, U <sub>e</sub> = 240 V, I <sub>e</sub> = 3 A conforming to IEC 60947-5-1 appendix A
[I <sub>th</sub> ] conventional enclosed thermal current	10 A
[U <sub>i</sub> ] rated insulation voltage	500 V (degree of pollution: 3) conforming to IEC 60947-1
[U <sub>imp</sub> ] rated impulse withstand voltage	6 kV conforming to IEC 60947-1
Resistance across terminals	<= 25 MOhm
Short circuit protection	10 A fuse protection by cartridge fuse type gG
Rated operational power in W	60 W DC-13 for 1000000 cycles, operating rate = 60 cyc/mn at 24 V, load factor = 0.5 (inductive load) conforming to IEC 60947-5-1 appendix C 45 W DC-13 for 1000000 cycles, operating rate = 60 cyc/mn at 48 V, load factor = 0.5 (inductive load) conforming to IEC 60947-5-1 appendix C 42 W DC-13 for 1000000 cycles, operating rate = 60 cyc/mn at 120 V, load factor = 0.5 (inductive load) conforming to IEC 60947-5-1 appendix C
Rated operational power in VA	525 VA AC-15 for 1000000 cycles, operating rate = 60 cyc/mn at 127 V 50/60 Hz, load factor = 0.5 (inductive load) 455 VA AC-15 for 1000000 cycles, operating rate = 60 cyc/mn at 230 V 50/60 Hz, load factor = 0.5 (inductive load) 385 VA AC-15 for 1000000 cycles, operating rate = 60 cyc/mn at 48 V 50/60 Hz, load factor = 0.5 (inductive load) 140 VA AC-15 for 1000000 cycles, operating rate = 60 cyc/mn at 24 V 50/60 Hz, load factor = 0.5 (inductive load)
Terminals description ISO n°1	(13-14)NO
Terminal identifier	(11-12)NC (13-14)NO
Product weight	0.07 kg

## Environment

Standards	EN 60947-5-1 IEC 60947-5-1 CSA C22.2 No 14
Ambient air temperature for operation	-25...70 °C
Ambient air temperature for storage	-40...70 °C
Vibration resistance	15 gn (f = 10...500 Hz) conforming to IEC 60068-2-6
Shock resistance	100 gn conforming to IEC 60068-2-27

## Dimensions

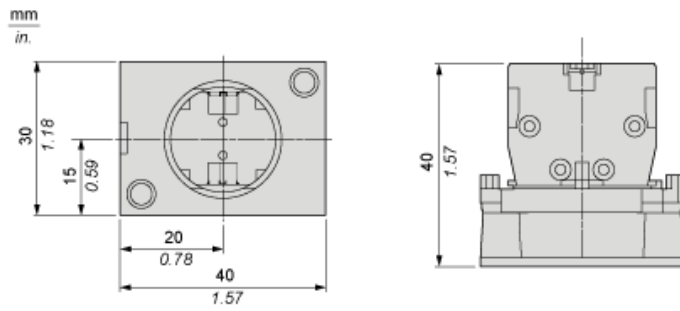

## Mounting

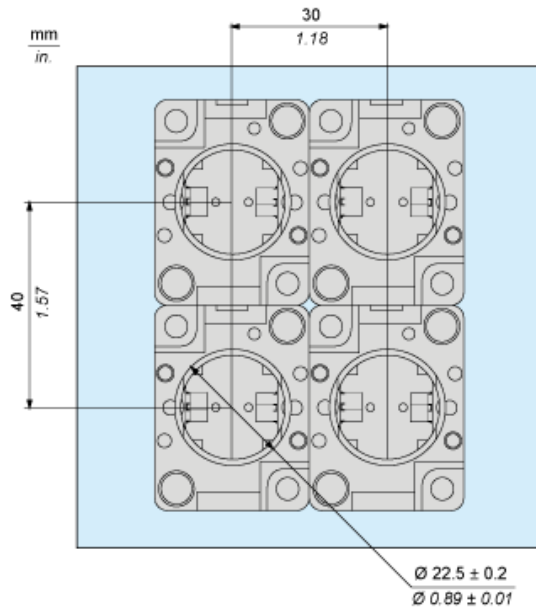

Rated Operational Power

AC Supply 50/60 Hz

Operating rate: 3600 operating cycles/hour. Load factor: 0.5.

Power broken in VA for 1 million operating cycles, AC-15 utilization category

Voltage	V	24	48	127	230
Inductive circuit	W	140	385	525	455

DC Supply

Operating rate: 3600 operating cycles/hour. Load factor: 0.5.

Power broken in W for 1 million operating cycles, DC-13 utilization category

Voltage	V	24	48	120
Inductive circuit	W	60	45	42