



Main

Range of product	Zelio Logic
Product or component type	Discrete I/O extension module

Complementary

Number of control scheme lines	120 with ladder programming
Cycle time	6...90 ms
Backup time	10 years at 25 °C
Clock drift	12 min/year at 0...55 °C
Checks	Program memory on each power up
[Us] rated supply voltage	12 V DC
Supply voltage limits	10.4...14.4 V
Reverse polarity protection	With
Discrete input number	8 conforming to EN/IEC 61131-2 type 1
Discrete input type	Resistive
Discrete input voltage	12 V DC
Discrete input current	4 mA
Counting frequency	1 kHz for discrete input
Voltage state 1 guaranteed	>= 5.6 V for I1...IA and IH...IR discrete input circuit >= 7 V for IB...IG used as discrete input circuit
Voltage state 0 guaranteed	<= 2.4 V for I1...IA and IH...IR discrete input circuit <= 3 V for IB...IG used as discrete input circuit
Current state 1 guaranteed	>= 0.5 mA for IB...IG used as discrete input circuit >= 2 mA for I1...IA and IH...IR discrete input circuit
Current state 0 guaranteed	< 0.9 mA for I1...IA and IH...IR discrete input circuit < 0.2 mA for IB...IG used as discrete input circuit
Input compatibility	3-wire proximity sensors PNP (discrete input)
Input impedance	2.7 kOhm (I1...IA and IH...IR discrete input circuit) 14 kOhm (IB...IG used as discrete input circuit)
Number of outputs	6 relay output(s)
Output voltage limits	5...30 V DC (relay output) 24...250 V AC (relay output)
Contacts type and composition	NO for relay output
Output thermal current	8 A for 4 outputs (relay output) 5 A for 2 outputs (relay output)
Electrical durability	500000 cycles at 24 V, 1.5 A (DC-12) for relay output conforming to EN/IEC 60947-5-1 500000 cycles at 24 V, 0.6 A (DC-13) for relay output conforming to EN/IEC 60947-5-1 500000 cycles at 230 V, 1.5 A (AC-12) for relay output conforming to EN/IEC 60947-5-1 500000 cycles at 230 V, 0.9 A (AC-15) for relay output conforming to EN/IEC 60947-5-1
Switching capacity in mA	>= 10 mA at 12 V (relay output)

Operating rate in Hz	10 Hz (no load) for relay output 0.1 Hz (at Ie) for relay output
Mechanical durability	10000000 cycles (relay output)
[Uimp] rated impulse withstand voltage	4 kV conforming to EN/IEC 60947-1 and EN/IEC 60664-1
Response time	5 ms (from state 1 to state 0) for relay output 10 ms (from state 0 to state 1) for relay output
Connections - terminals	Screw terminals, solid cable 2 x 0.2...2 x 1.5 mm ² / AWG 24...AWG 16 AWG Screw terminals, solid cable 1 x 0.2...1 x 2.5 mm ² / AWG 25...AWG 14 AWG Screw terminals, semi-solid cable 1 x 0.2...1 x 2.5 mm ² / AWG 25...AWG 14 AWG Screw terminals, flexible cable with cable end 2 x 0.25...2 x 0.75 mm ² / AWG 24...AWG 18 AWG Screw terminals, flexible cable with cable end 1 x 0.25...1 x 2.5 mm ² / AWG 24...AWG 14 AWG
Tightening torque	0.5 N.m
Overvoltage category	III conforming to EN/IEC 60664-1
Product weight	0.22 kg

Environment

Product certifications	CSA C-Tick GL GOST UL
Standards	EN/IEC 60068-2-27 Ea EN/IEC 60068-2-6 Fc EN/IEC 61000-4-11 EN/IEC 61000-4-12 EN/IEC 61000-4-2 level 3 EN/IEC 61000-4-3 EN/IEC 61000-4-4 level 3 EN/IEC 61000-4-5 EN/IEC 61000-4-6 level 3
IP degree of protection	IP40 (front panel) conforming to IEC 60529 IP20 (terminal block) conforming to IEC 60529
Environmental characteristic	Low voltage directive conforming to EN/IEC 61131-2 EMC directive conforming to EN/IEC 61131-2 zone B EMC directive conforming to EN/IEC 61000-6-4 EMC directive conforming to EN/IEC 61000-6-3 EMC directive conforming to EN/IEC 61000-6-2
Disturbance radiated/conducted	Class B conforming to EN 55022-11 group 1
Pollution degree	2 conforming to EN/IEC 61131-2
Ambient air temperature for operation	-20...55 °C conforming to IEC 60068-2-1 and IEC 60068-2-2 -20...40 °C in non-ventilated enclosure conforming to IEC 60068-2-1 and IEC 60068-2-2
Ambient air temperature for storage	-40...70 °C
Operating altitude	2000 m
Altitude transport	<= 3048 m
Relative humidity	95 % without condensation or dripping water

I/O Extension Modules

Mounting on 35 mm/1.38 in. DIN Rail

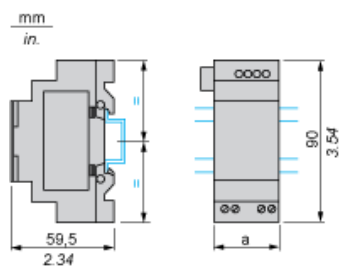

Screw Fixing (Retractable Lugs)

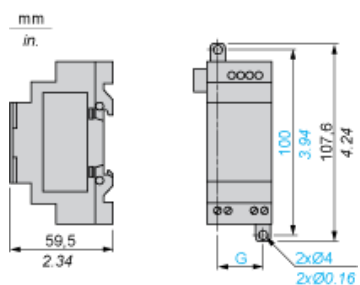

SR3	a (mm/in.)	G (mm/in.)
XT61••	3,5 / 0.13	25 / 0.98
XT101••	72 / 2.83	60 / 2.36
XT141••	72 / 2.83	60 / 2.36

Connection of Smart Relays on DC Supply, with Analog I/O Extension Module

Connection Alternatives

0 - 10 V	0 - 20 mA	Pt100
2	0	0
1	1	0
0	2	0
1	0	1
0	1	1

Application Example with 1 x 0 - 10 V Input and 1 x Pt100 Input

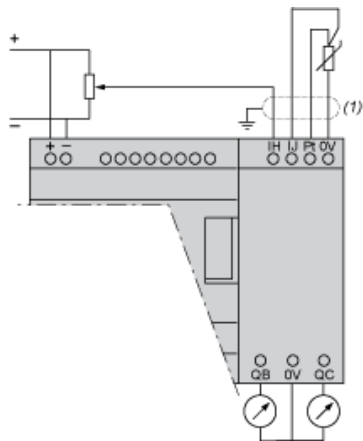

(1) Screened cables, maximum length 10 m/32.80 ft.

Application Example with 1 x 0 - 20 mA Input and 1 x 0 - 10 V Input

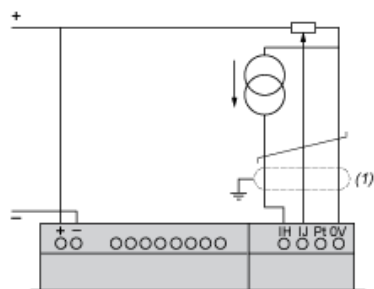

(1) Screened cables, maximum length 10 m/32.80 ft.

Compact and Modular Smart Relays

Electrical Durability of Relay Outputs

(in millions of operating cycles, conforming to IEC/EN 60947-5-1)

DC-12 (1)

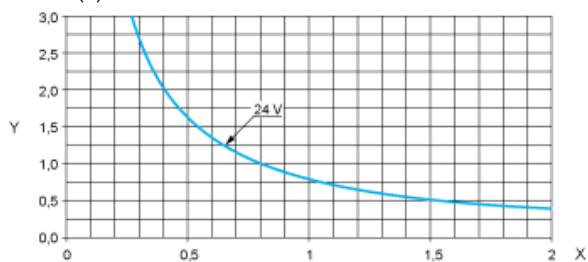

X: Current (A)

Y: Millions of operating cycles

(1) DC-12: control of resistive loads and of solid state loads isolated by opto-coupler, $L/R \leq 1$ ms.

DC-13 (1)

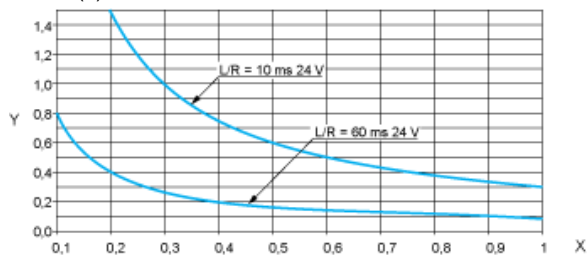

X: Current (A)

Y: Millions of operating cycles

(1) DC-13: switching electromagnets, $L/R \leq 2 \times (U_e \times I_e)$ in ms, U_e : rated operational voltage, I_e : rated operational current (with a protection diode on the load, DC-12 curves must be used with a coefficient of 0.9 applied to the number in millions of operating cycles).